

WP 3100
ТЕХНИЧЕСКИ КАТАЛОГ
TECHNICAL CATALOGUE TECHNISCHER KATALOG CATALOG TEHNIC

Съдържание
Contents
Inhalt
Continut

3 - камерна система 3-chamber system / 3-Kammer System / Sistem de 3 camere	1 - 7
Монтажи Assemblies / Montageschemas / Montaje	8 - 18
Фрезоване Milling / Frasen / Realizare	19 - 20
Схеми Montageschema / Scheme / Schema	21 - 23
Усилители Reinforced profiles / Verstaerkungsprofile / Armature	24 - 25
Формули Formulas / Formeln / Formule	26 - 27

ТЕХНИЧЕСКИ КАТАЛОГ
PVC СИСТЕМИ

TECHNICAL CATALOGUE
PVC SYSTEMS

TECHNISCHER KATALOG
PVC SYSTEME

CATALOG TEHNIC
SISTEME PVC



3 - КАМЕРА СИСТЕМА

3-chamber system / 3-Kammer System/
Sistem de 3 camere

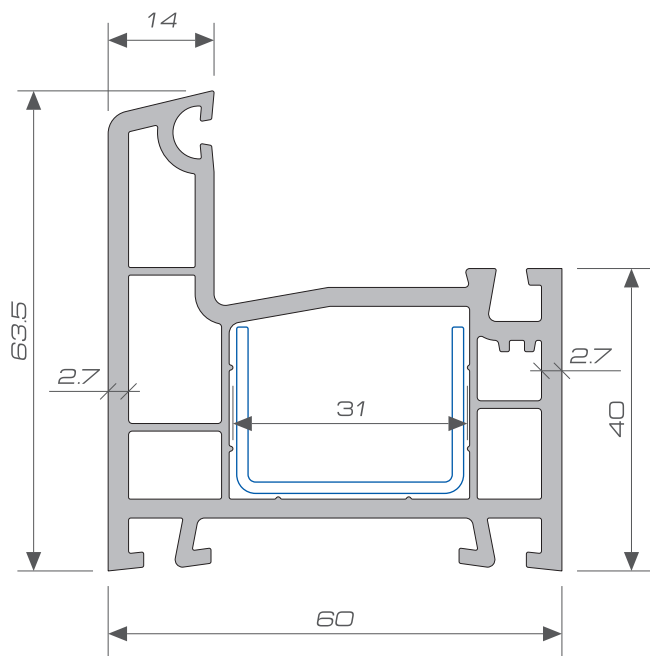

KACA
Rahmenprofil
Frame profile
Profil toc

WP 3101

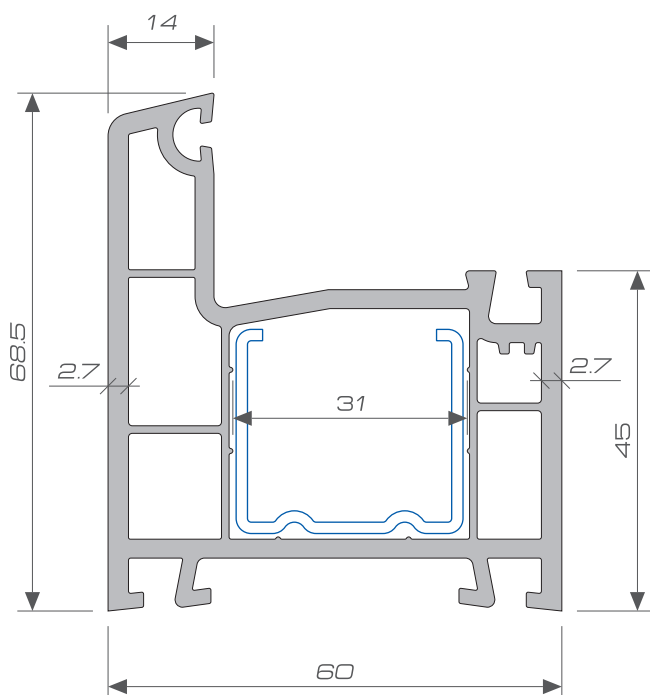

KACA
Rahmenprofil
Frame profile
Profil toc

WP 3111

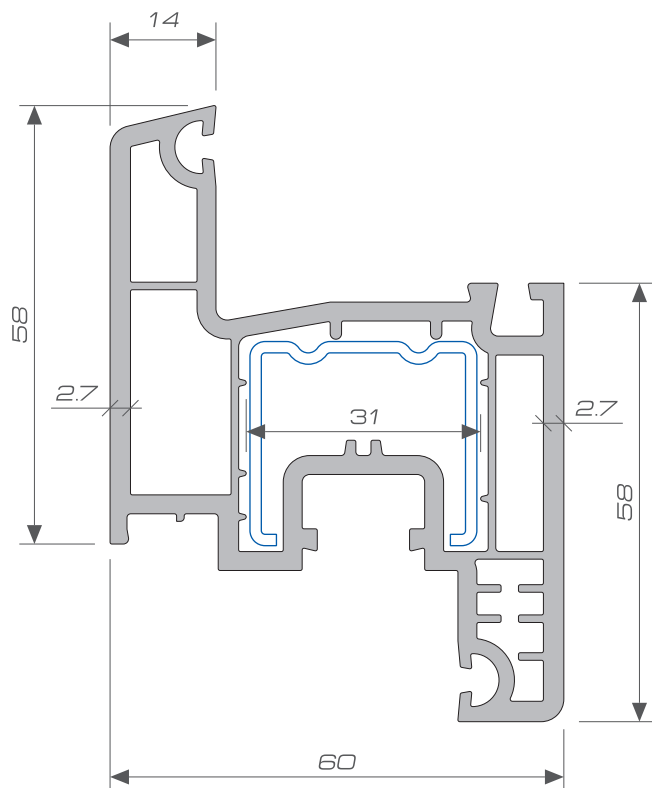

КРИЛО
Fluegelprofil
Sash profile
Profil anpa

WP 3102

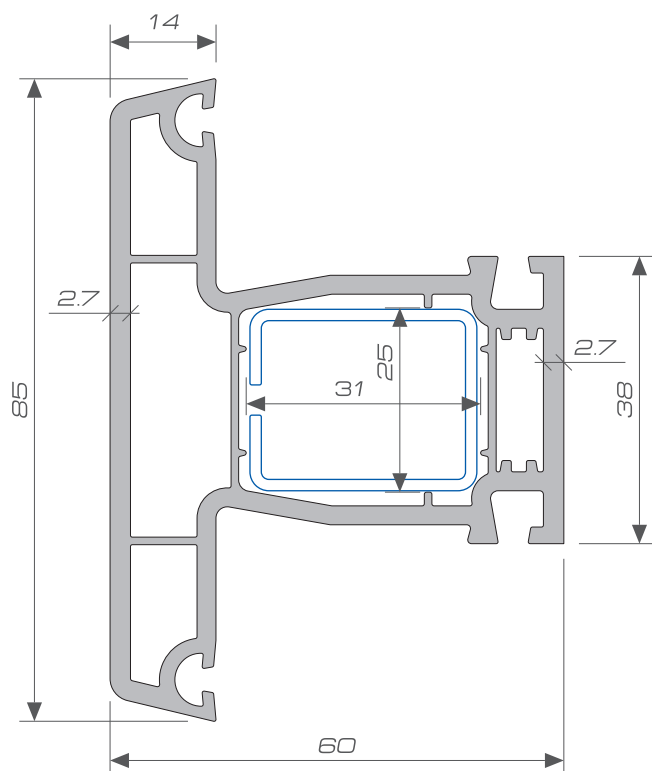

ДЕЛИТЕЛ
Kaempfer
Mullion profile
Profil traversa

WP 3103

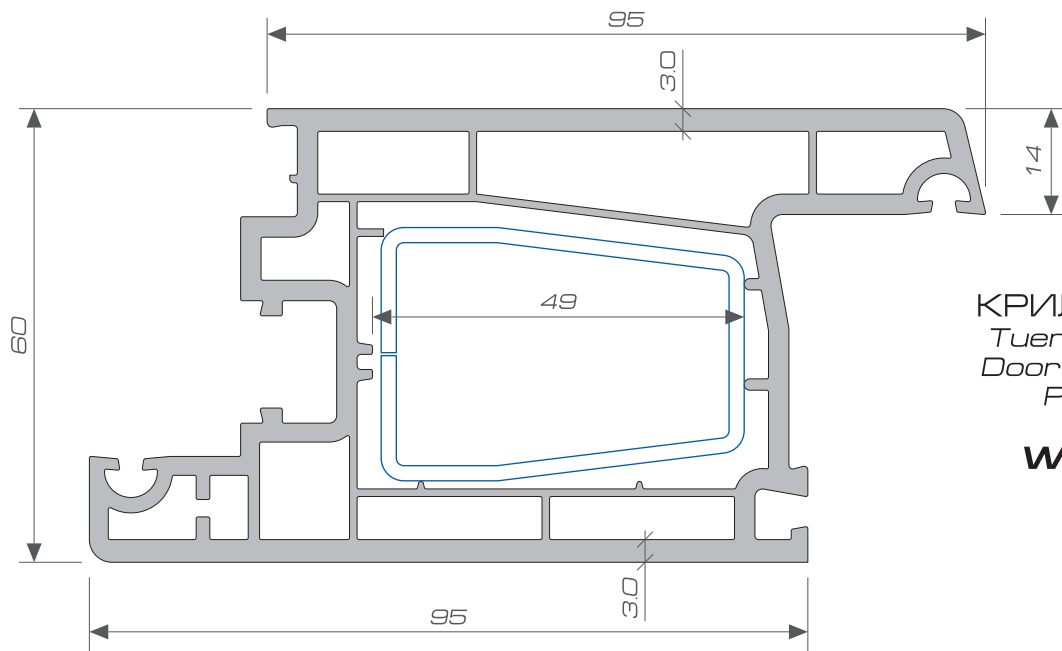

КРИЛО ВРАТА
 Tuerfluegelprofil
 Door sash profile
 Profil usa

WP 4104

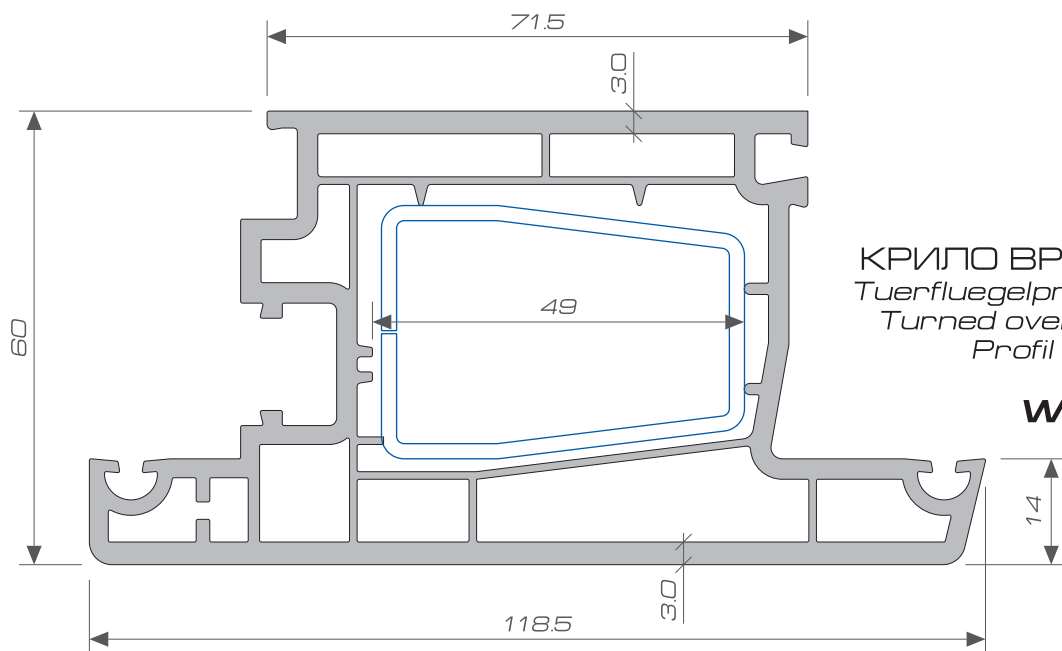

КРИЛО ВРАТА ОБЪРНАТО
 Tuerfluegelprofil aussen oeffnend
 Turned over door sash profile
 Profil usa exterior

WP 4105

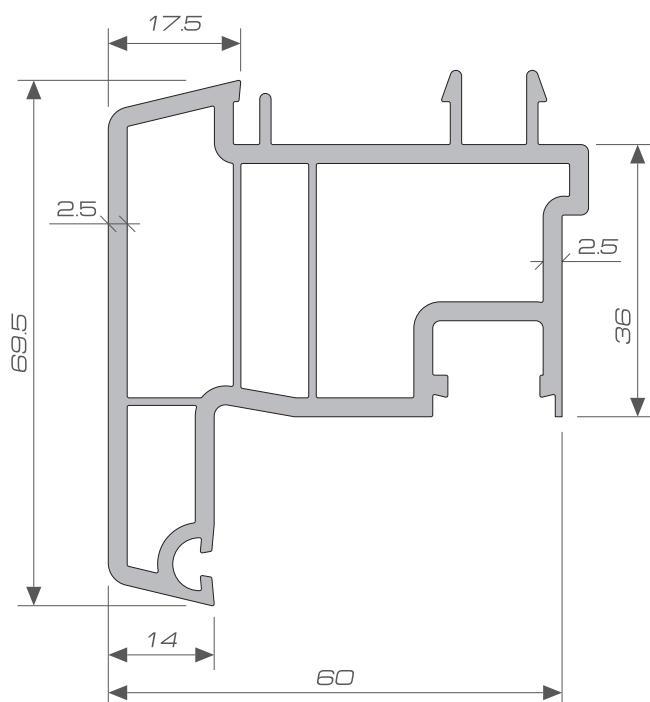

ПОДВИЖЕН ДЕЛИТЕЛ
Stulpprofil
Lap joint profile
Profil inversor

WP 4106

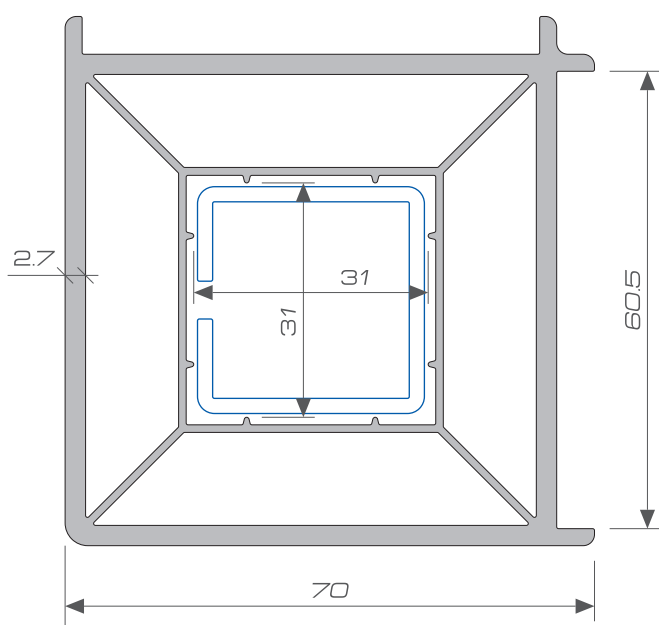

ЪГЛОВ ПРОФИЛ 90°
Eckpfosten
Corner profil
Profil colt 90°

WP 4107

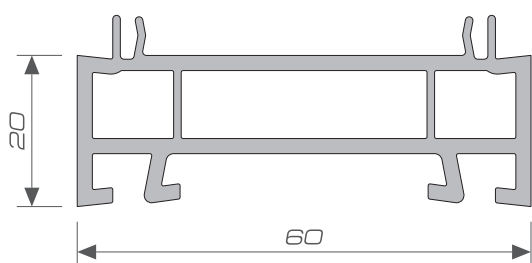

ПРОФИЛ УДЪЛЖИТЕЛ
Verlaengerung
Frame extension
Inversor

WP 4108

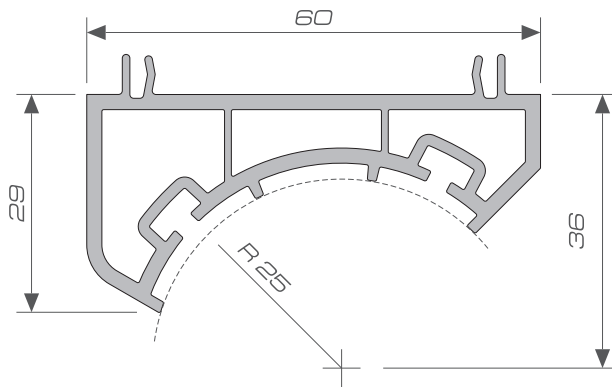

АДАПТОР
 Eckprofil variabler winkel
 Corner lag profile
 Profil adaptor

WP 4109

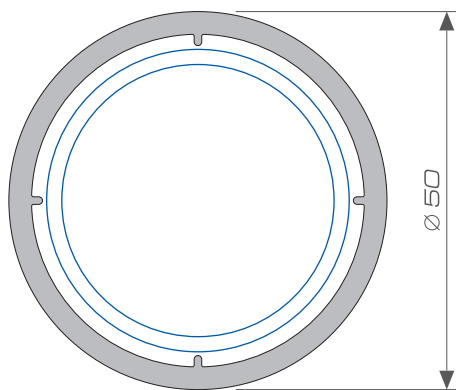

ТРЪБА
 Rohr variabler winkel
 Pipe profile
 Profil teava

WP 4111

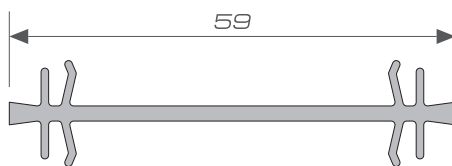

ПРИСЪЕДИНИТЕЛ
 Verbindungsprofil
 Coupling profile
 Profil conector

WP 4112

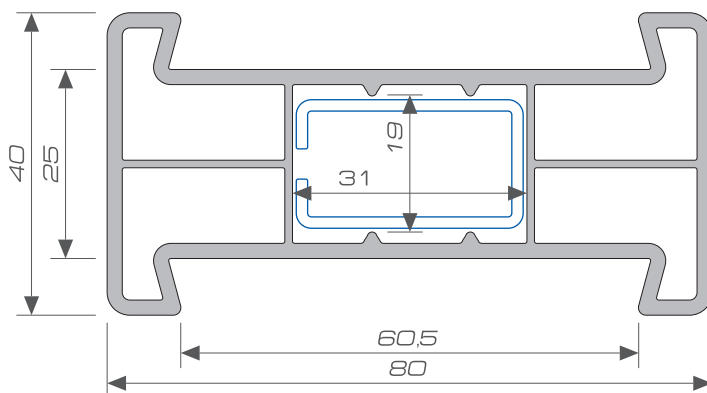

ПРИСЪЕДИНИТЕЛ
 Verbindungsprofil
 Coupling profile
 Profil conector

WP 4113

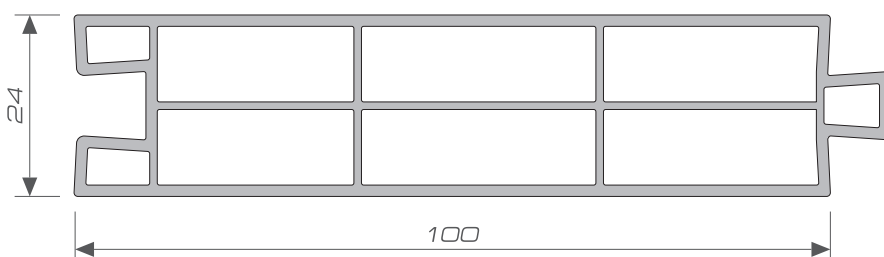

ПАНЕЛ 24 mm
 PVC Bindeplatte 24 mm
 PVC panel 24 mm
 Lambriu 24 mm

WP 4119

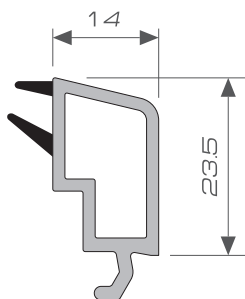

СТЪКЛОДЪРЖАТЕЛ 24 mm

*Glasleiste 24
Glass bead 24
Bagheta 24 mm*

WP 4120

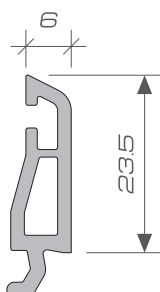

СТЪКЛОДЪРЖАТЕЛ 32 mm

*Glasleiste 32
Glass bead 32
Bagheta 32 mm*

WP 4130

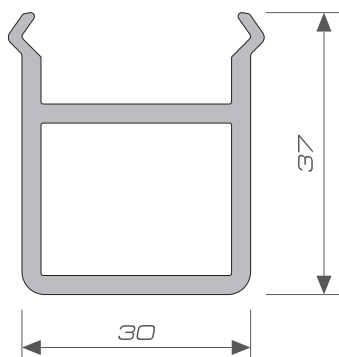

ПОВДИГАЩ ПРОФИЛ

*lifting profile
Hebeprofil*

WP 4123

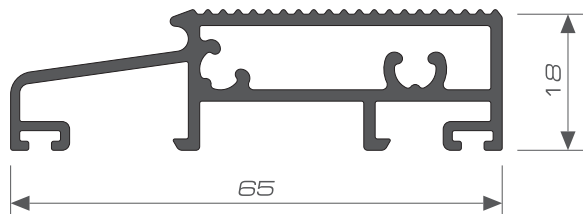

АЛУМИНИЕВ ПРАГ

*Aluminium Tuerschwelle
Aluminium door - sill
Prag din aluminiu*

WP 4065

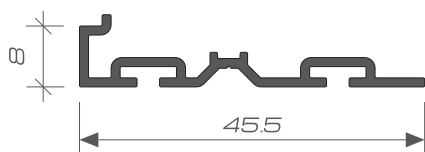

ПРОФИЛ ЗА ВРАТА
*Zusaetzliches Profil fuer Tuer
Additional profile for door
Profil suplimentar penru usa*

WP 4066

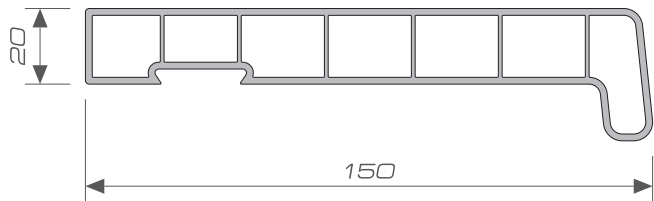

WP 4114

ПОДПРОЗОРЕЧЕН ПРОФИЛ
Fensterbank
Under window profile
Profil glaf

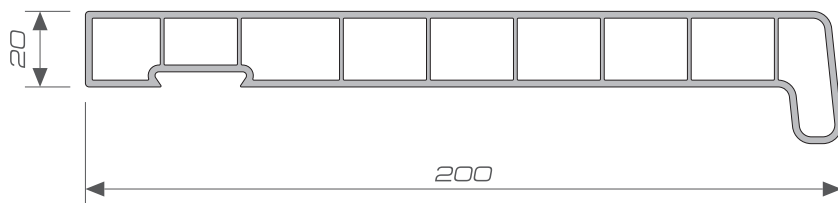

WP 4115

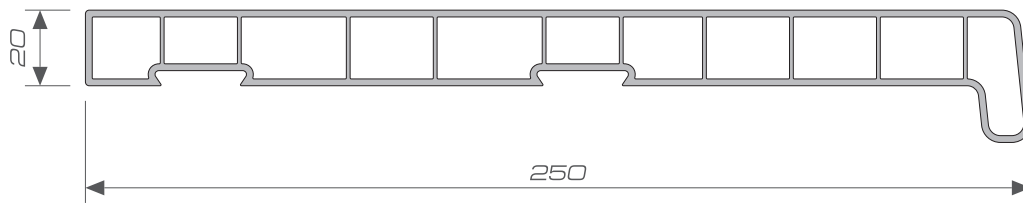

WP 4116

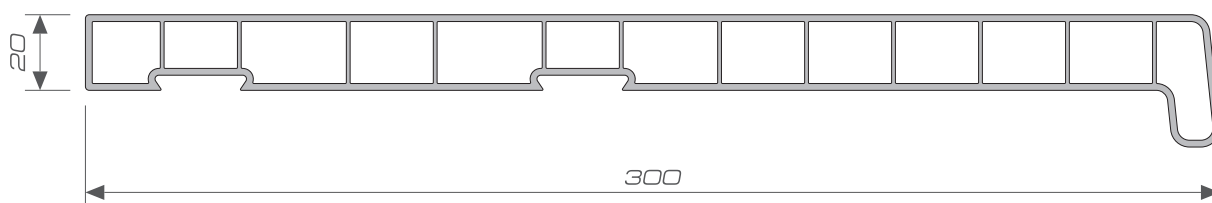

WP 4117

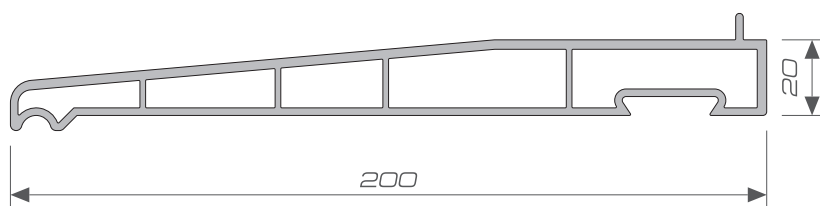

WP 4125

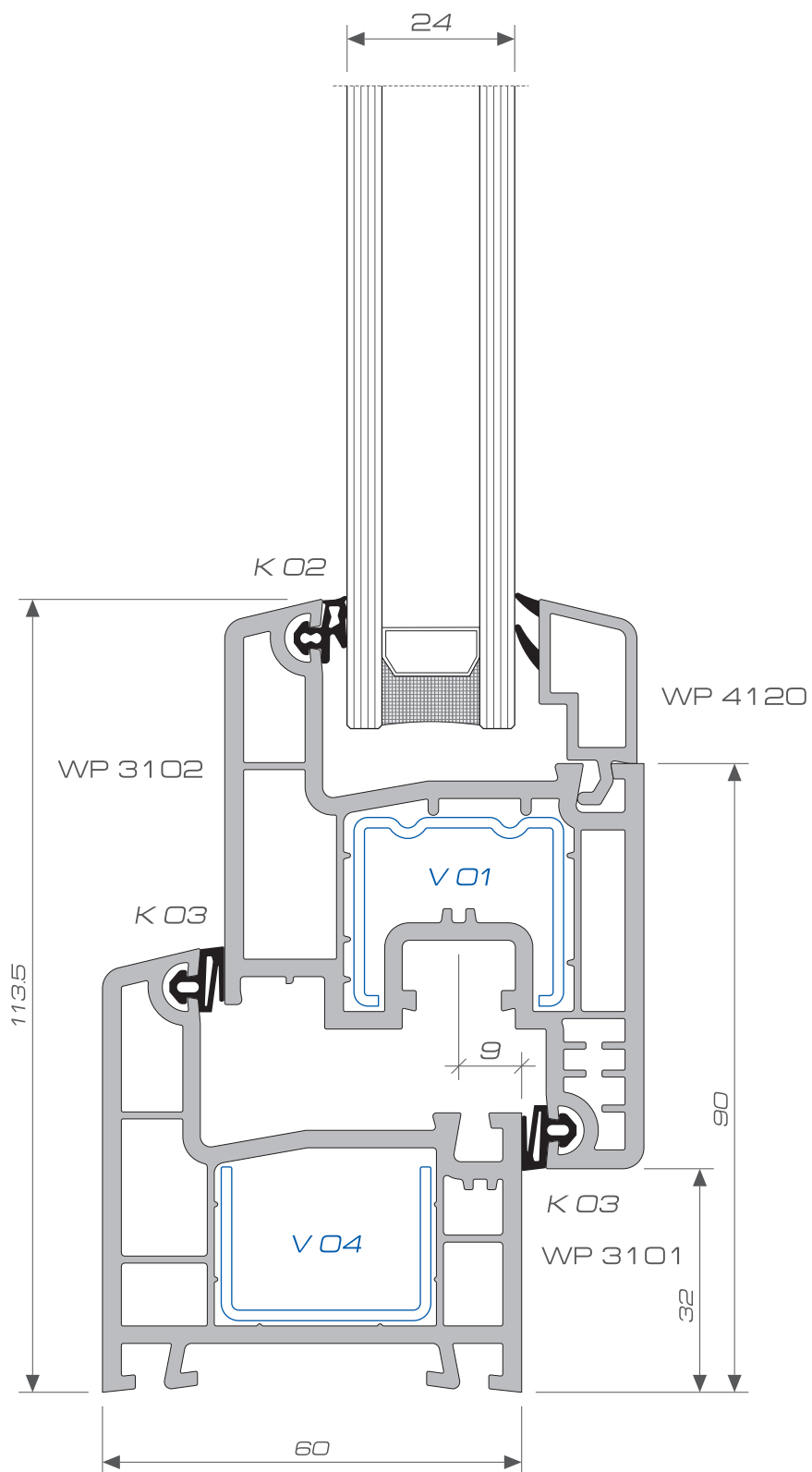

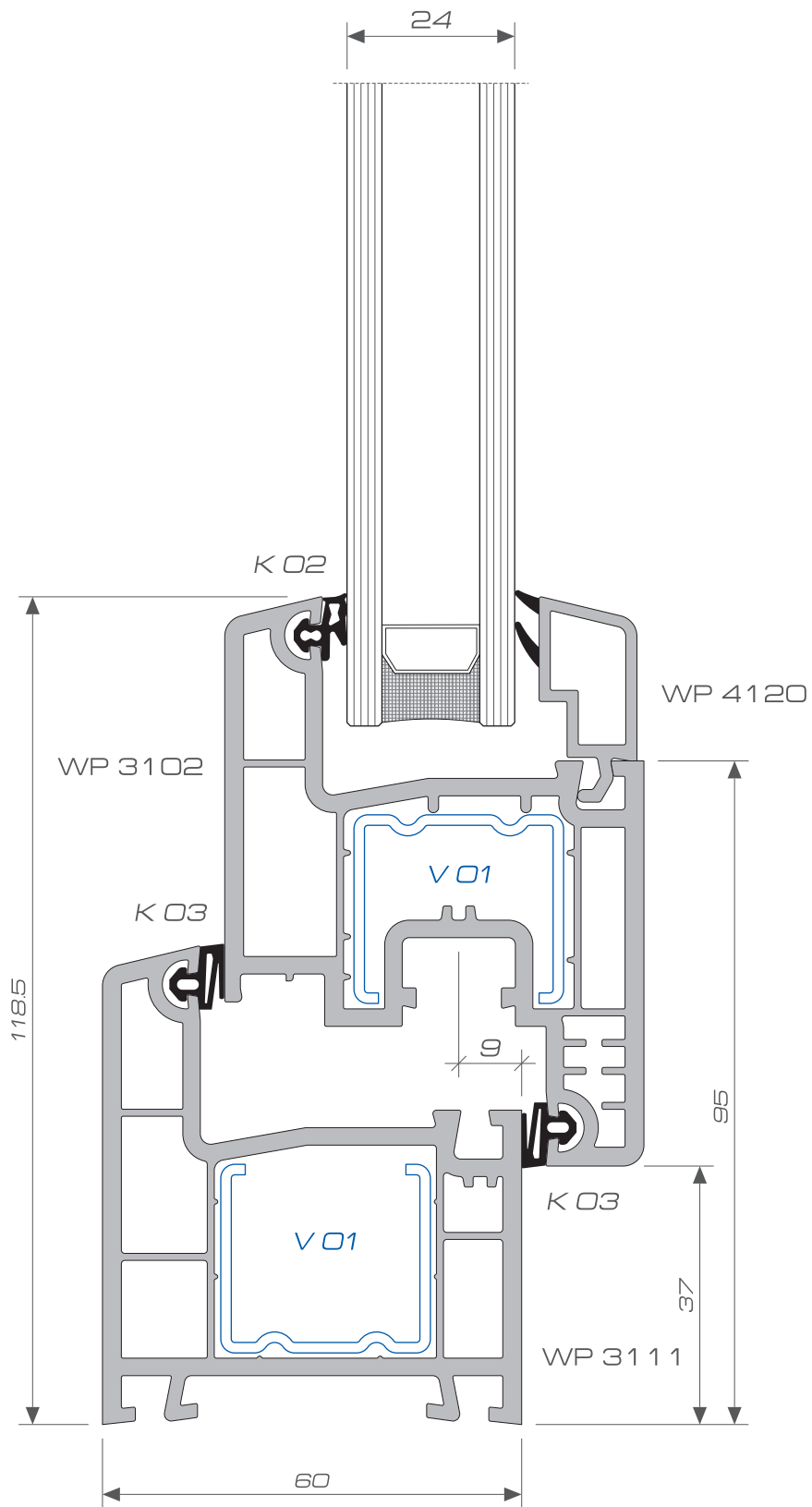

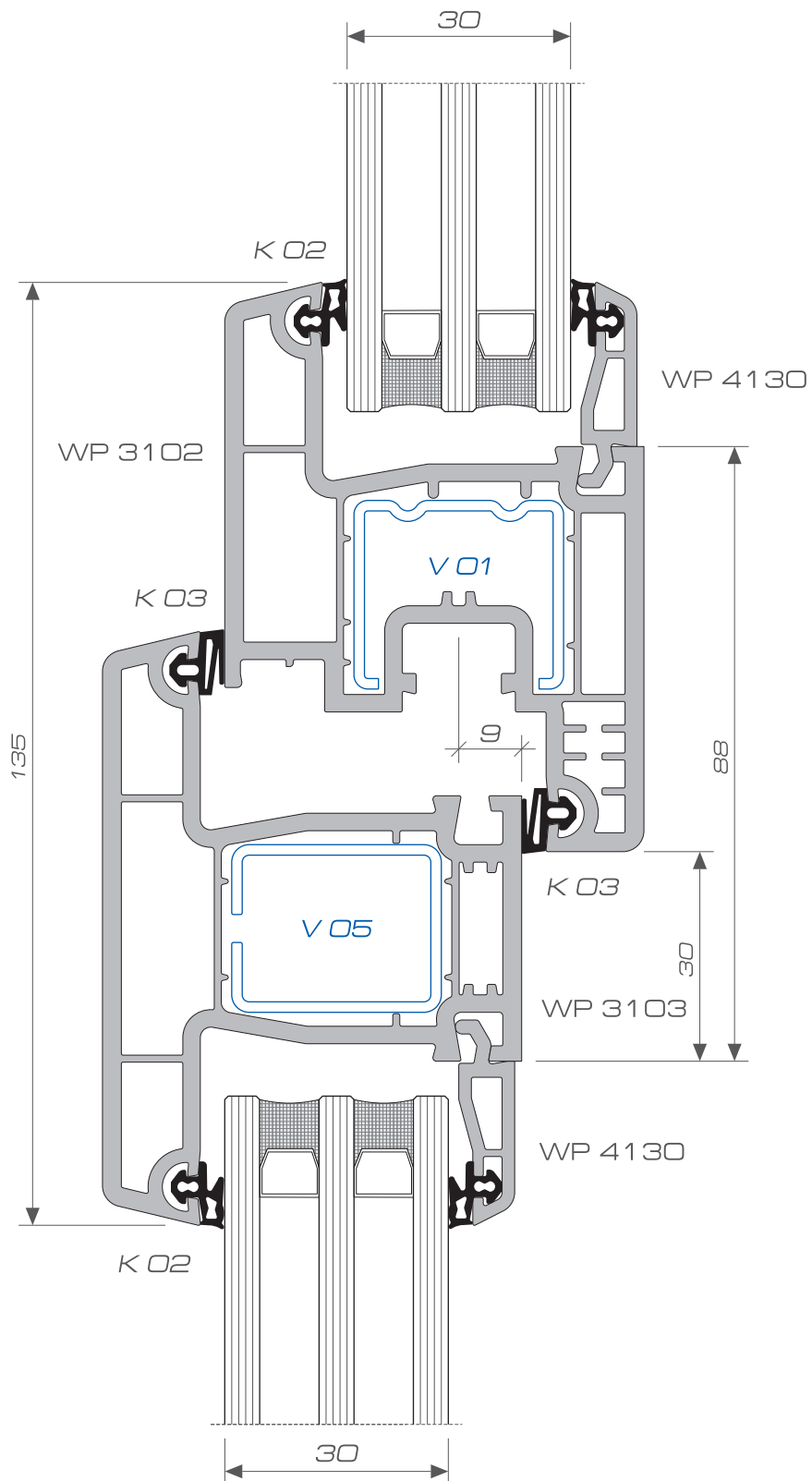

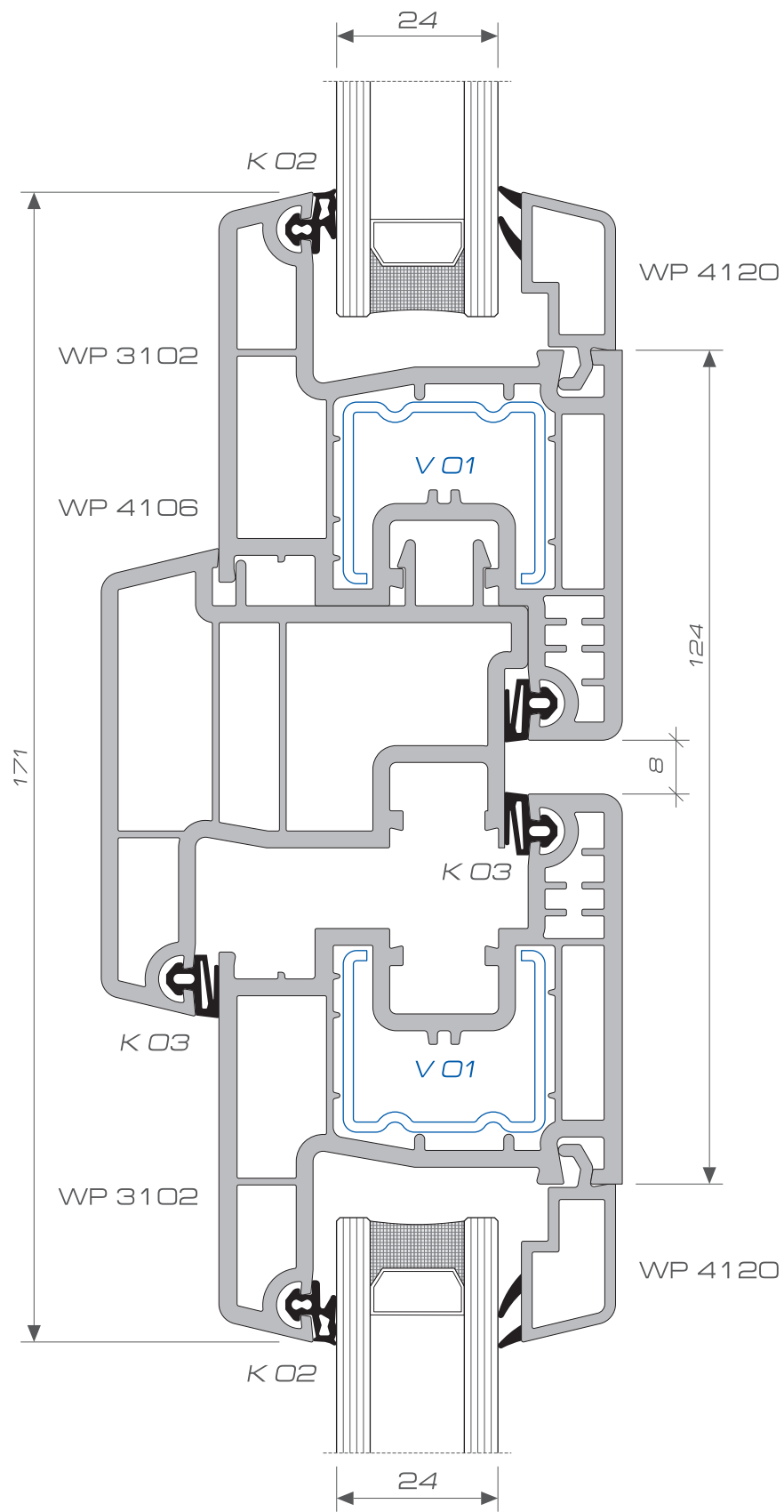

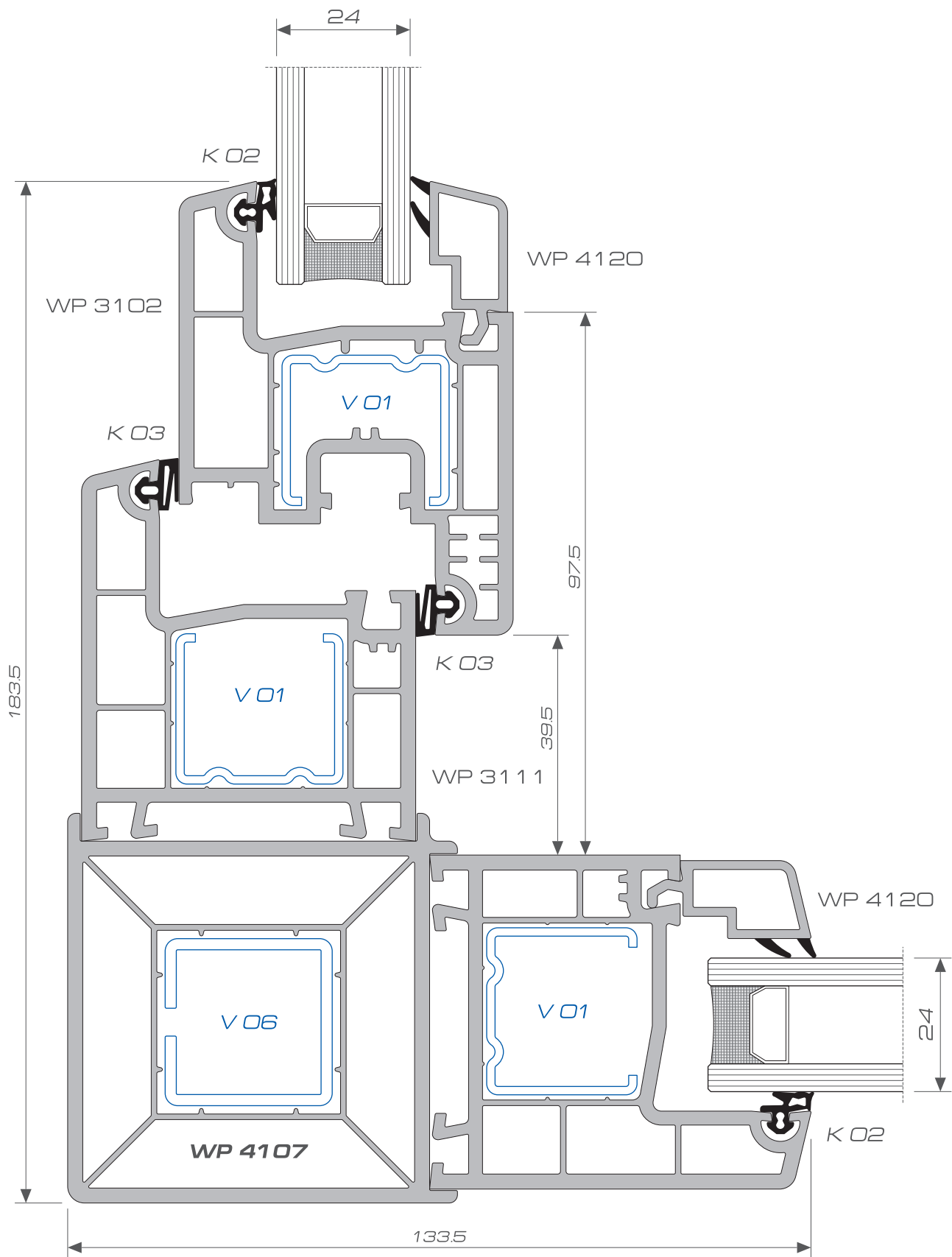

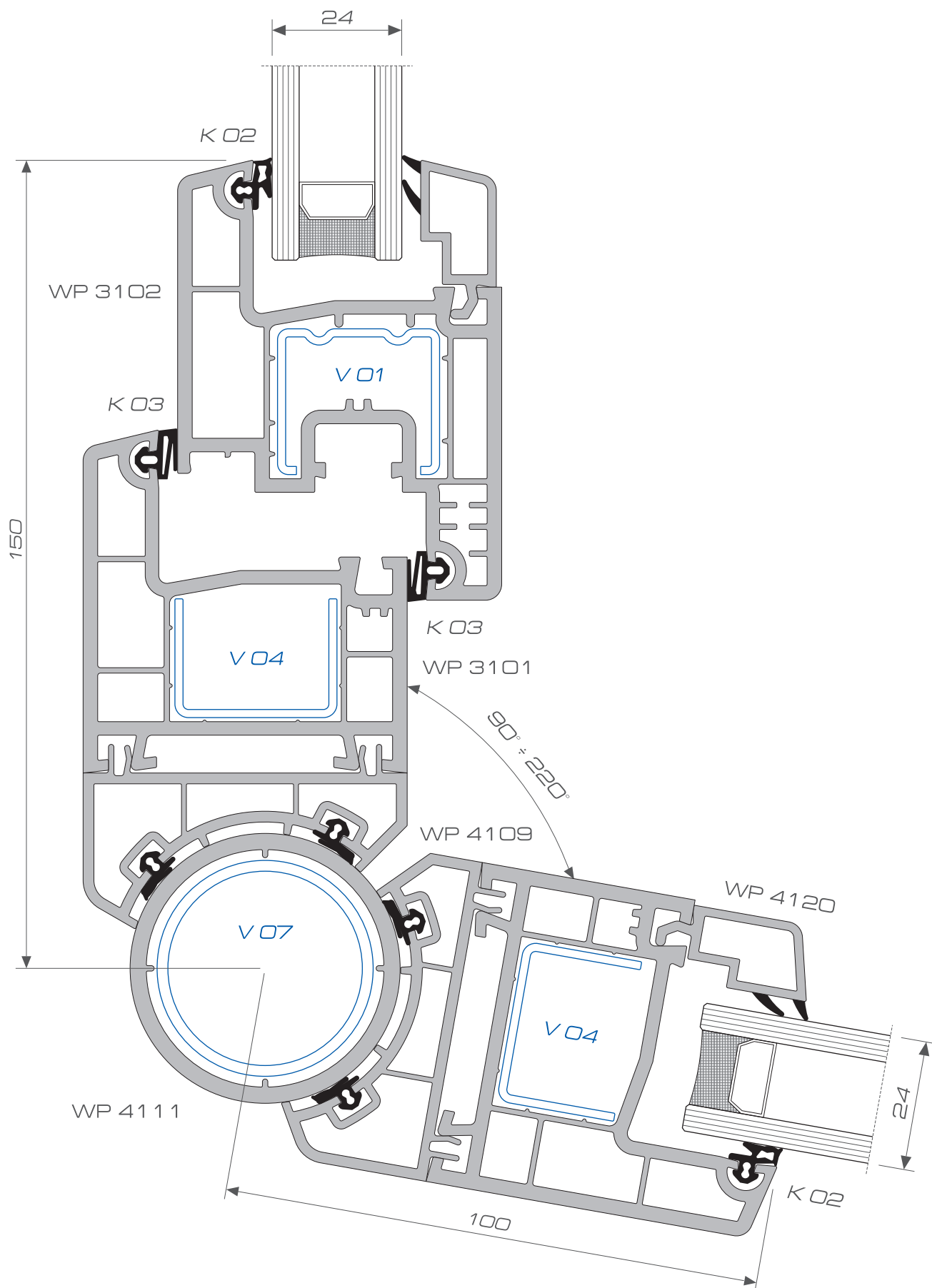

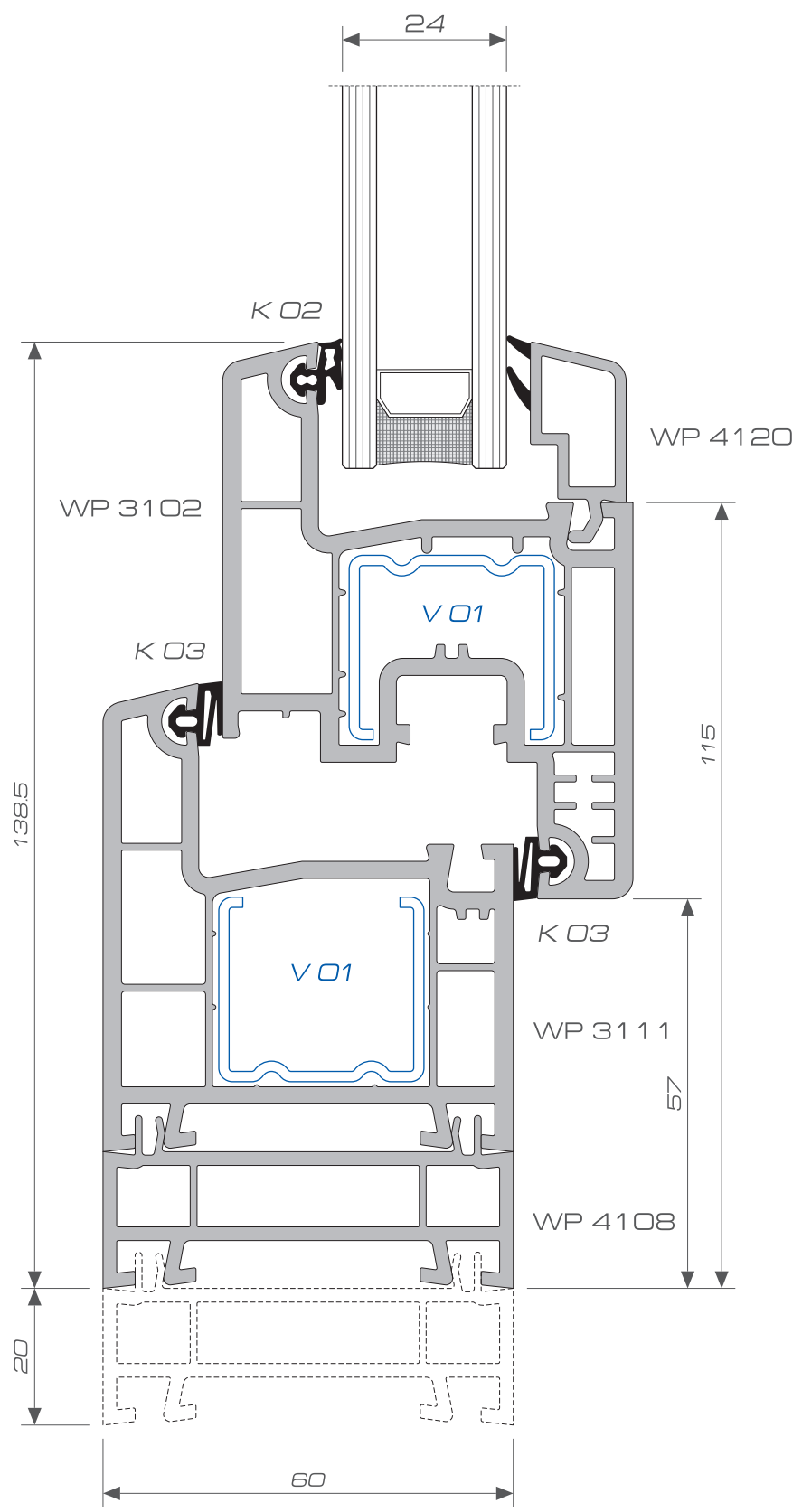

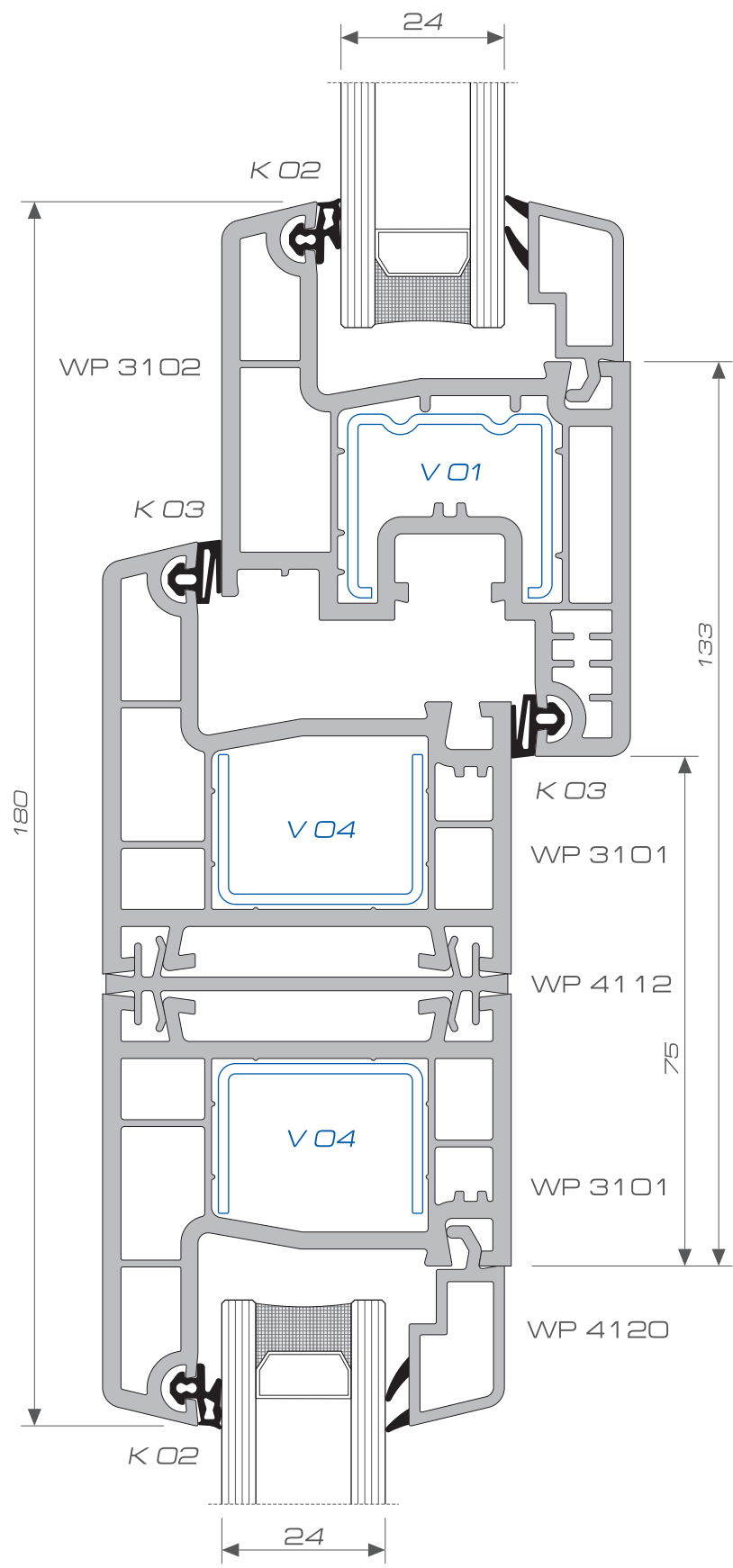

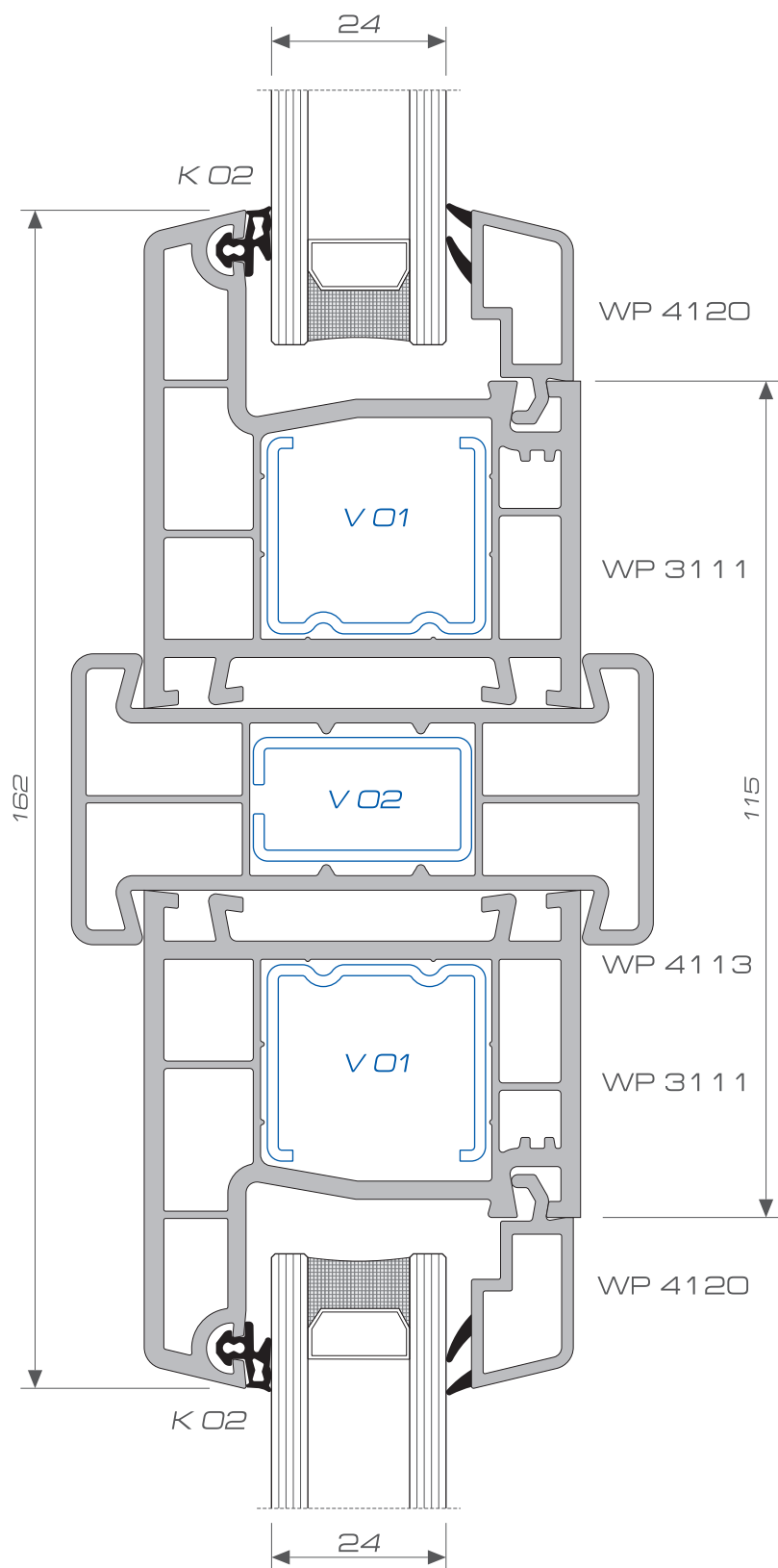

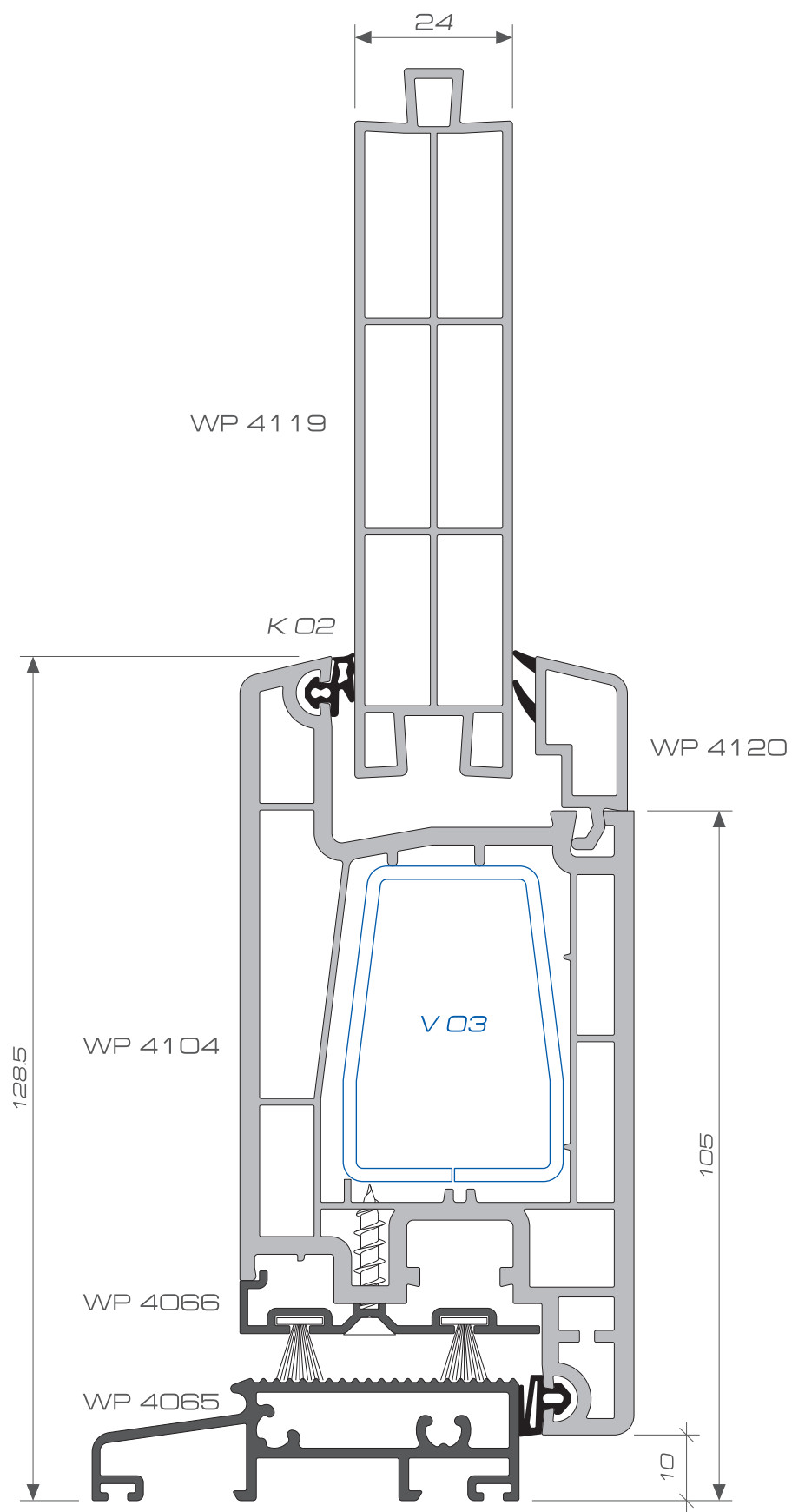



СХЕМА ЗА ВОДООТЛИВАНЕ

Drainage diagram / Abwasserungsschema / Schema pentru scurgere apa

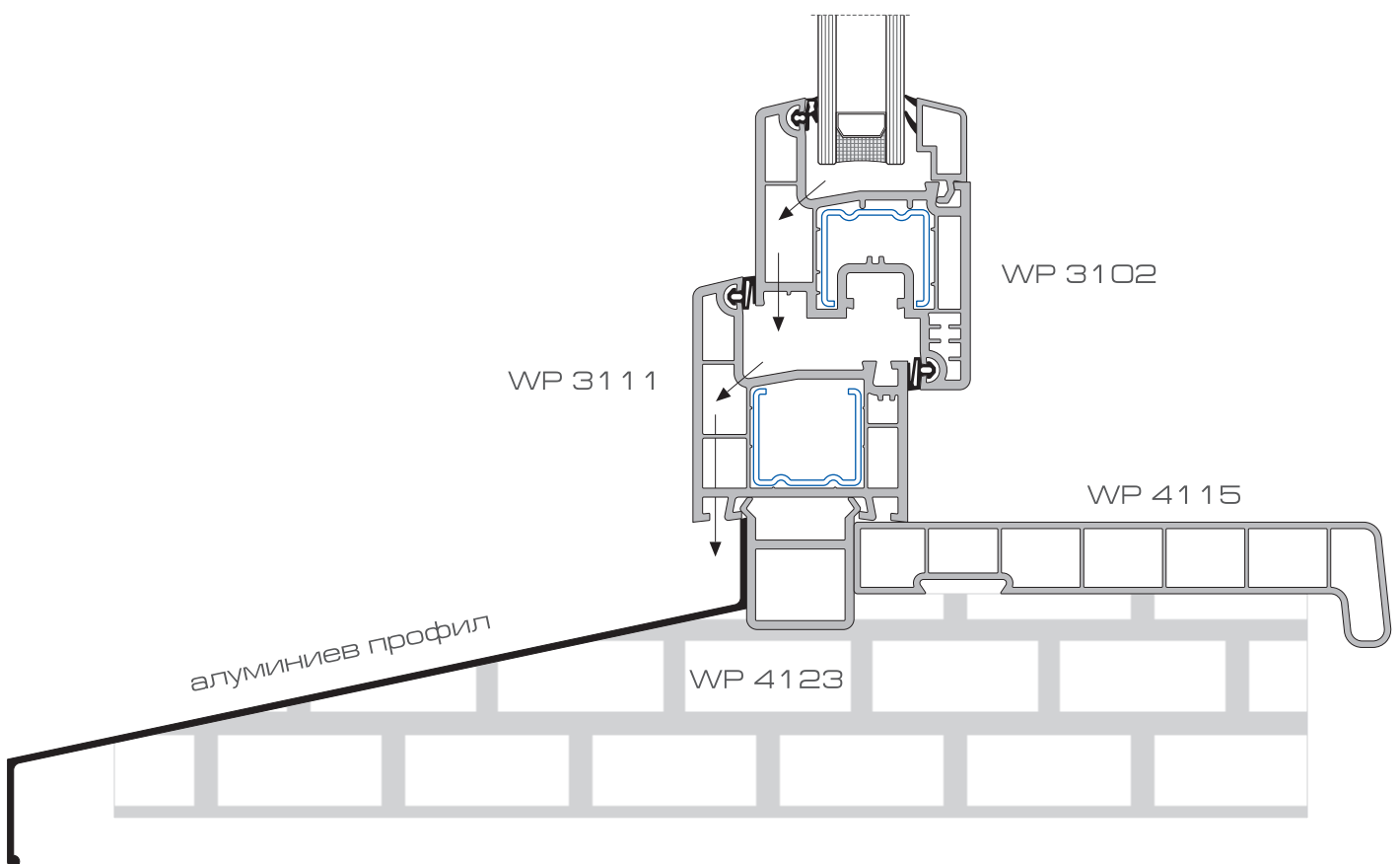
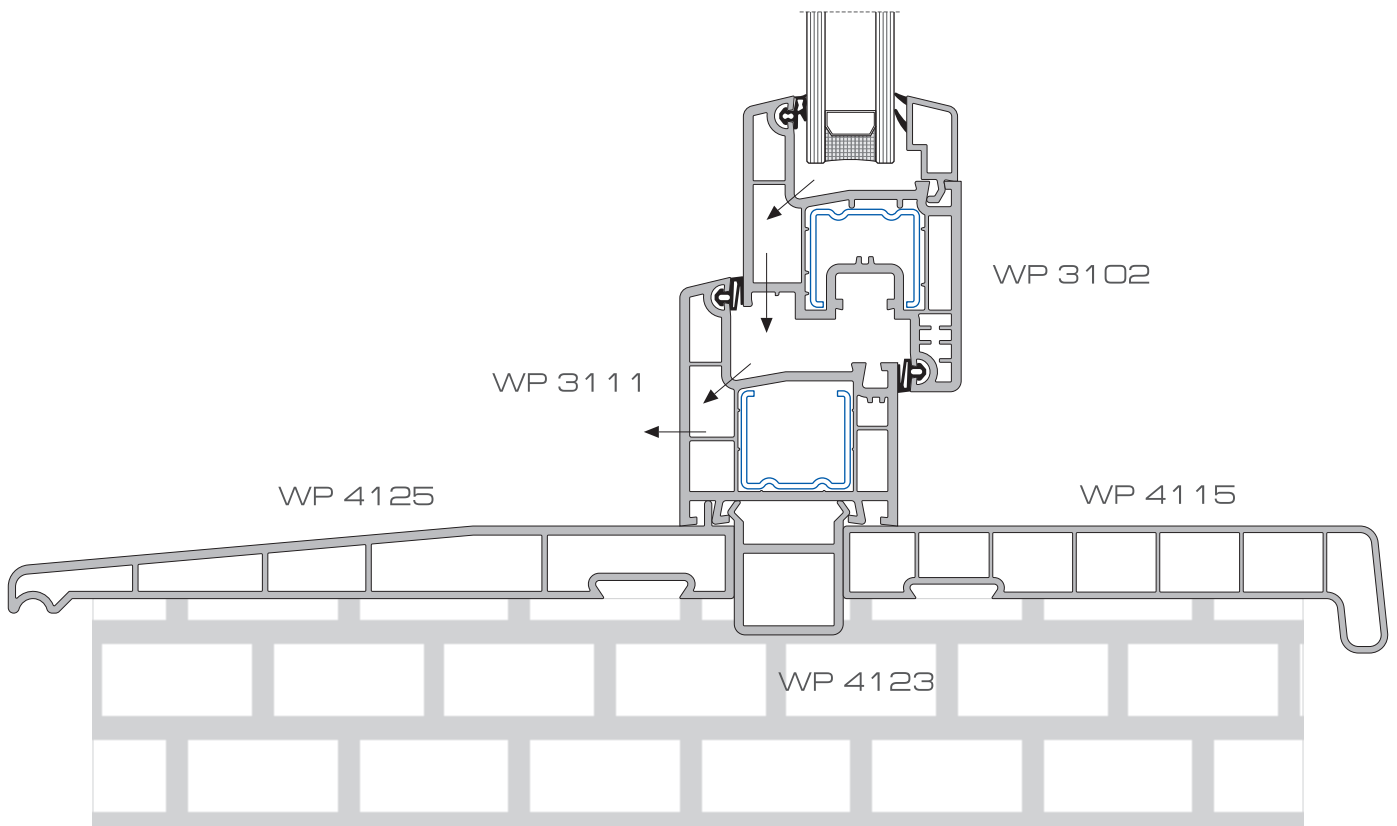

СХЕМА ЗА ФРЕЗОВАНЕ НА ДЕЛИТЕЛ

Mullion milling / Kaempferfrasenschema / Schema pentru frezarea traversei

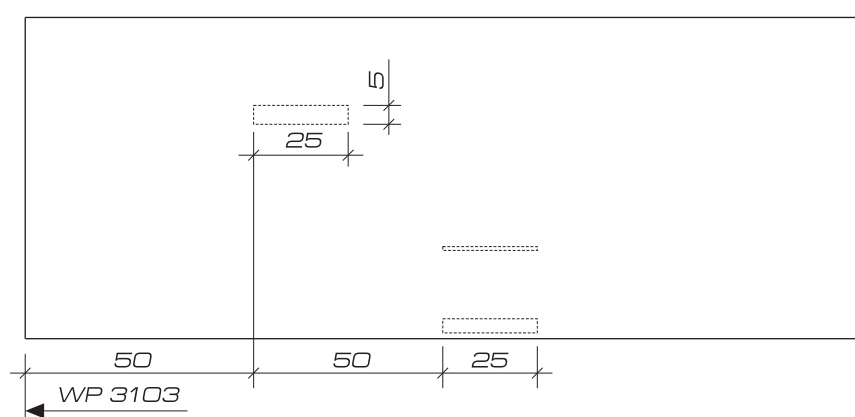
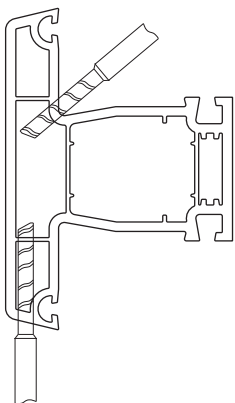
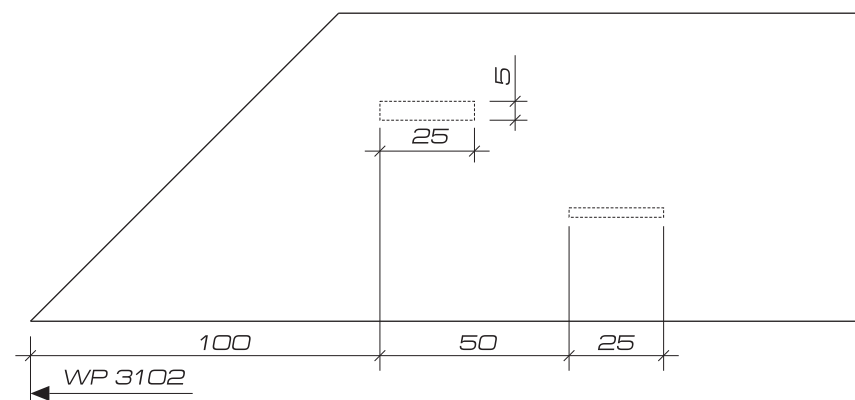
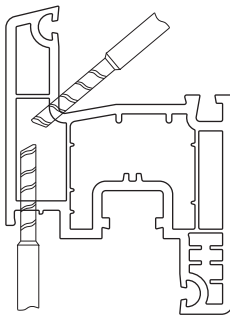
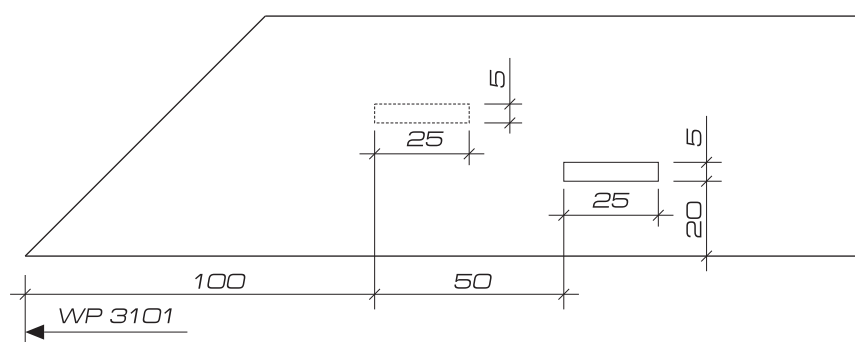
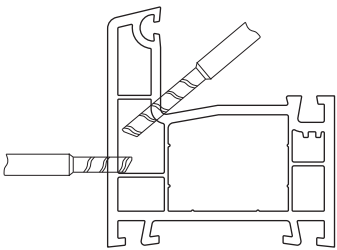
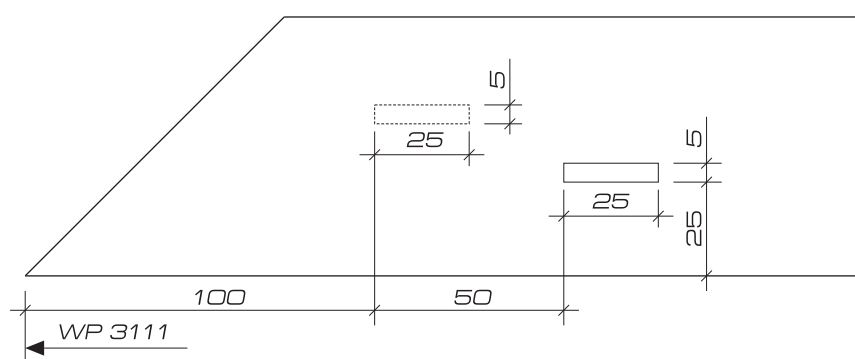
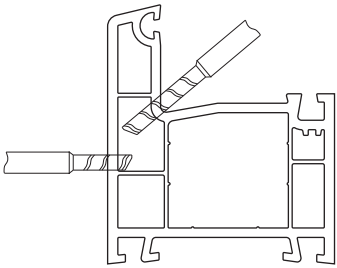
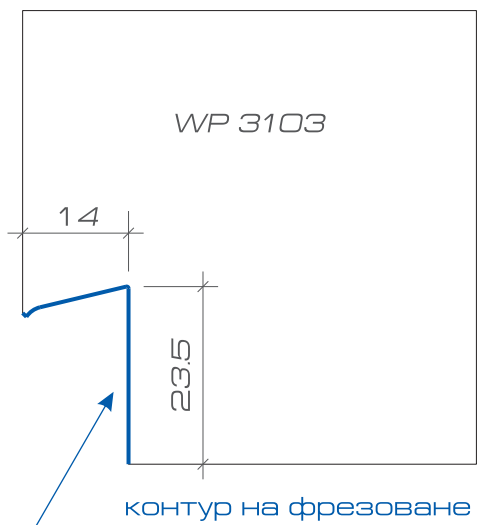

контур на фрезование
line of milling
Fräsekontur
contur pentru frezare

ПЛАСТМАСОВА СГЛОБКА
plastic joint
Plastikzusammensetzung
conector din plastic

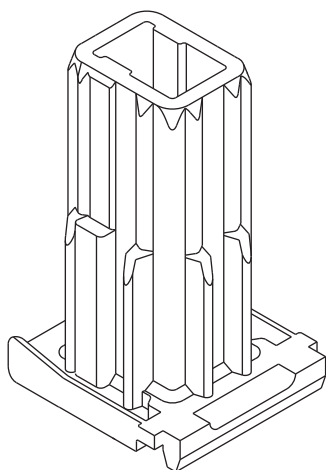

МЕТАЛНА СГЛОБКА
metal joint
Metallzusammensetzung
conector metalic



СХЕМА ДЕЛИТЕЛ - КАСА

Schema Kaempfer - Rahmen/ Scheme mullion - frame/
Schema de montaj traversa - toc

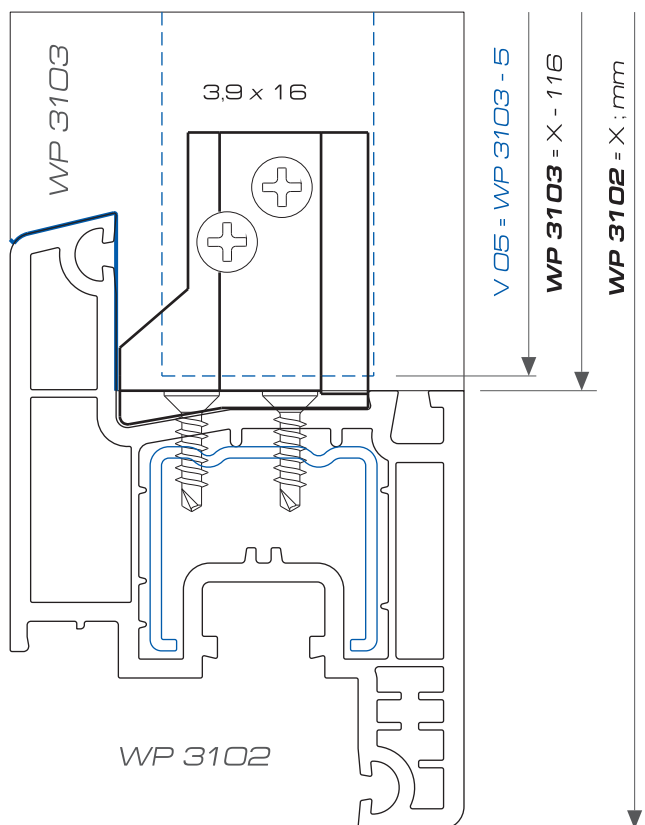
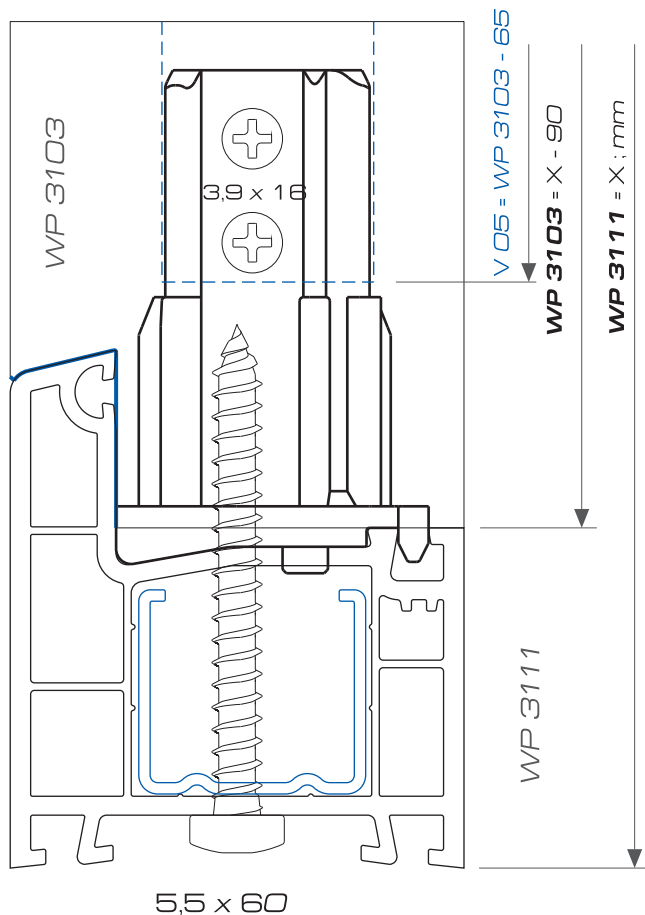
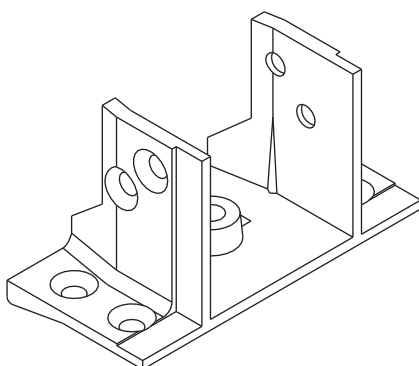

СХЕМА ДЕЛИТЕЛ - ДЕЛИТЕЛ

Schema Kaempfer - Kaempfer/ Scheme mullion - mullion

Schema de montaj traversa - traversa

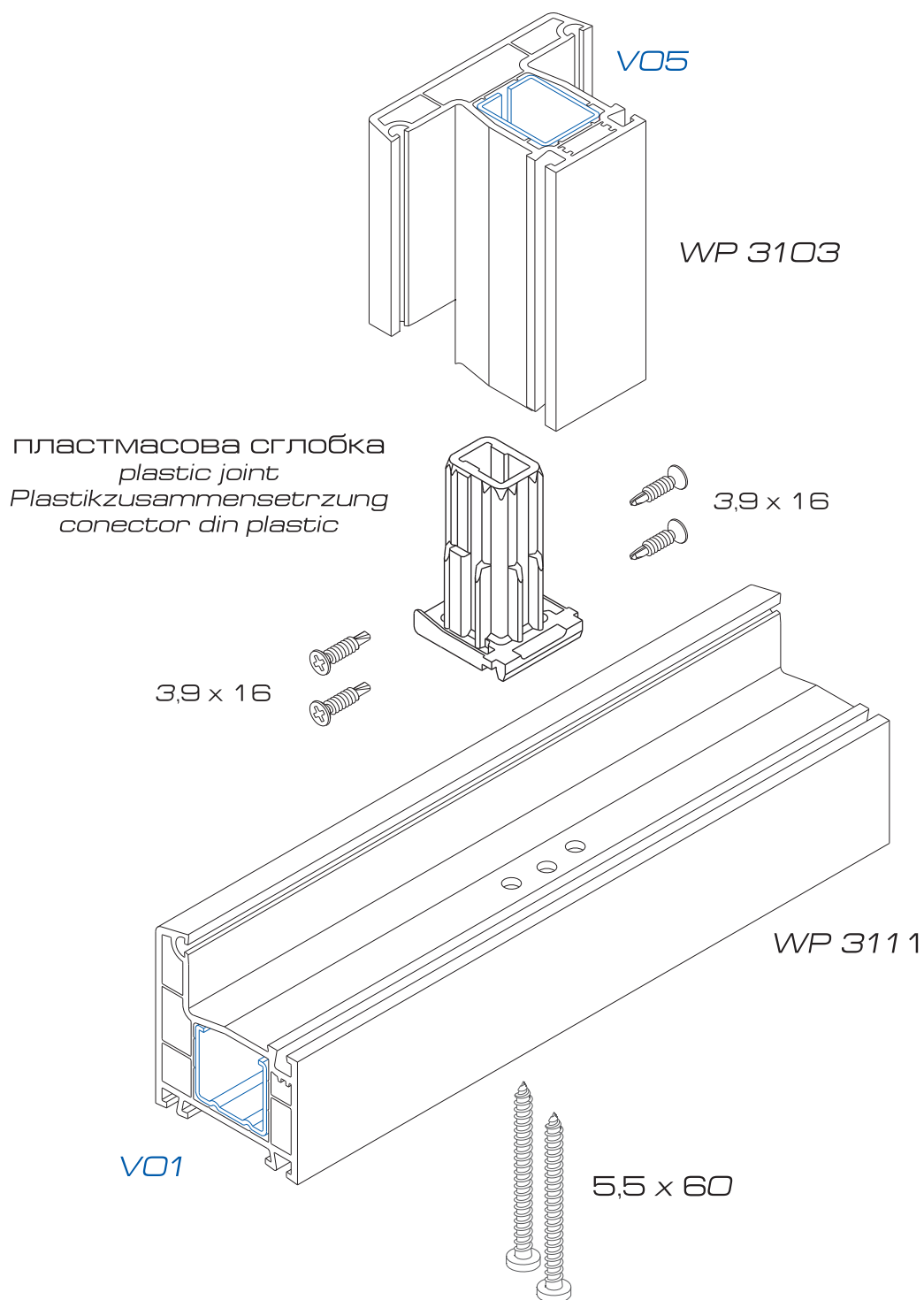

СХЕМА ПОДВИЖЕН ДЕЛИТЕЛ

Schema Stulpkaempfer/ Scheme lap joint profile/ Schema de montaj inversor

капачка
cap
abdeckkappe
capacele

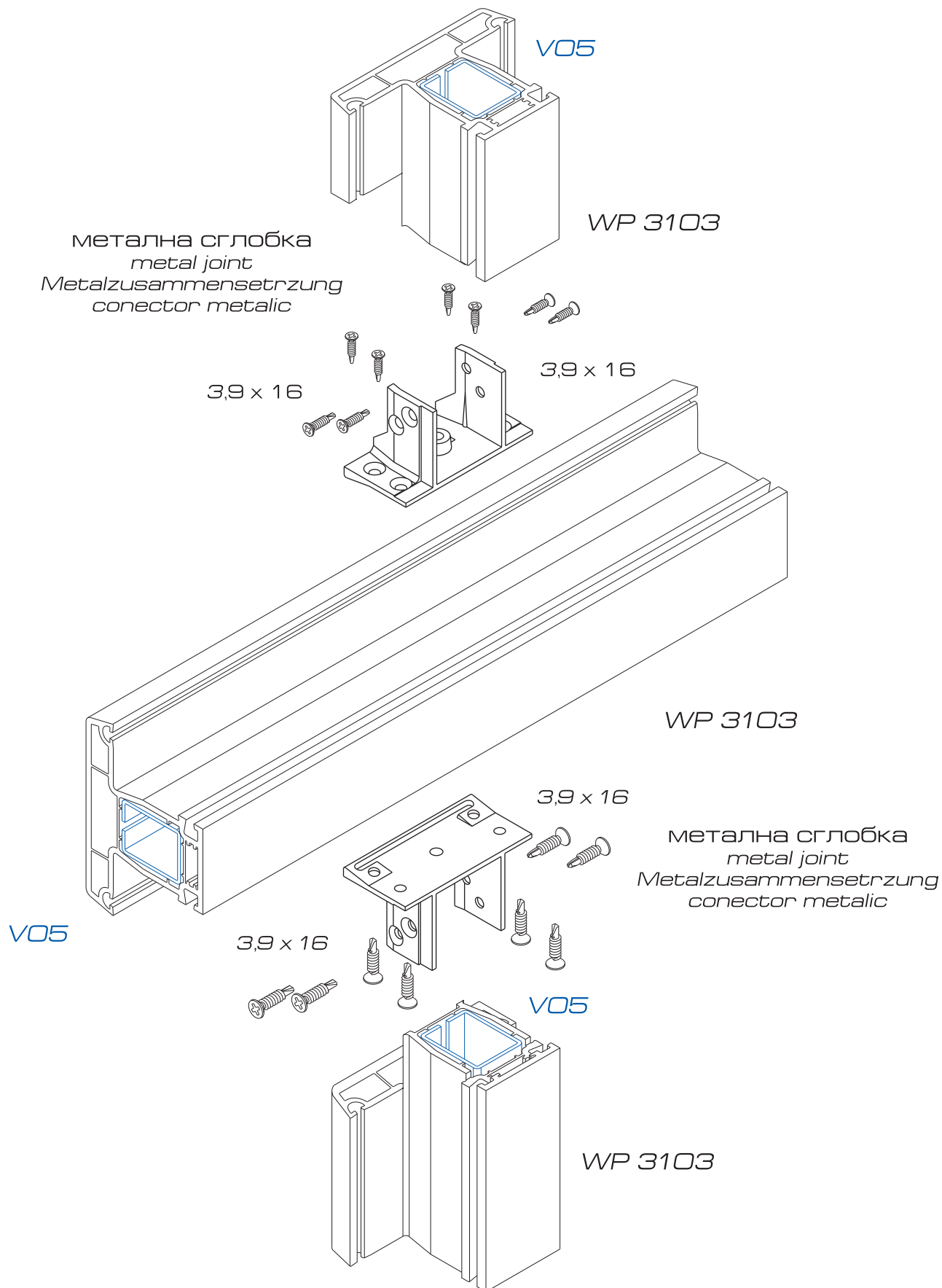
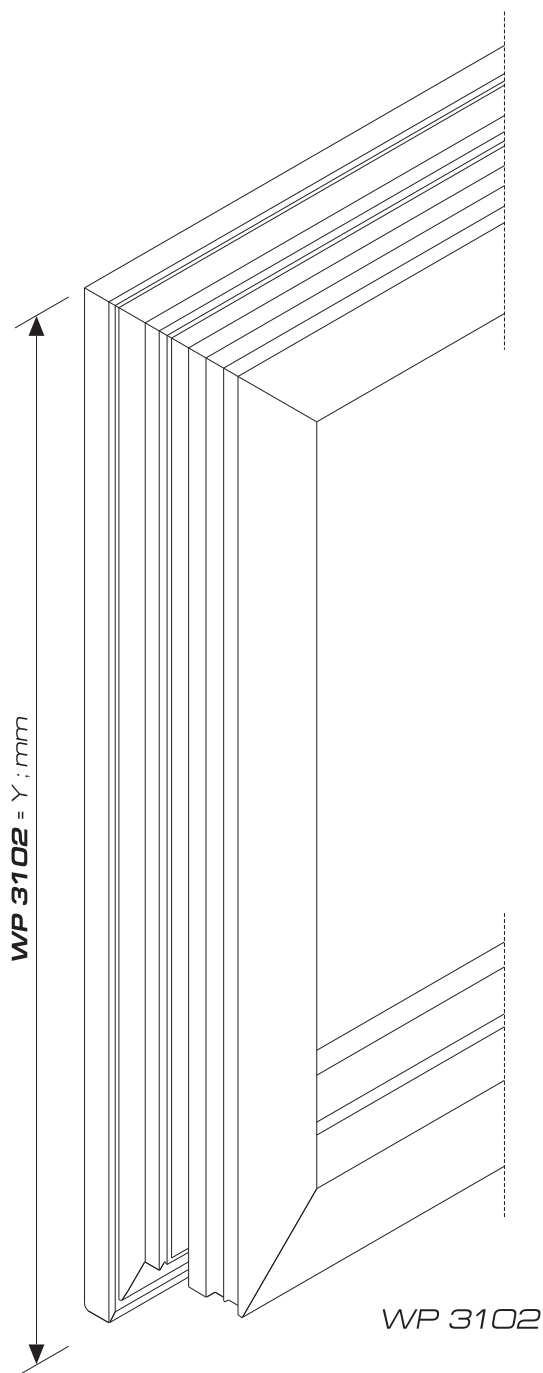
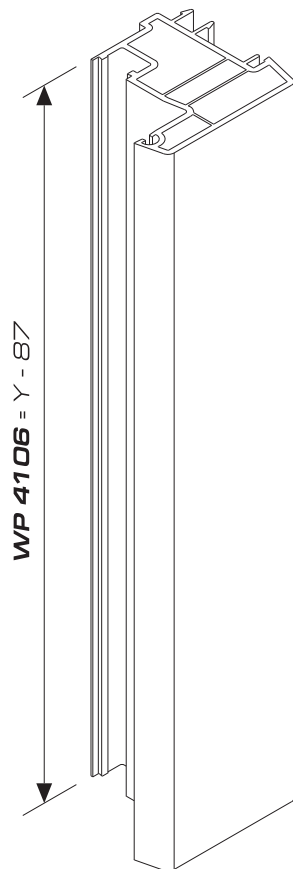
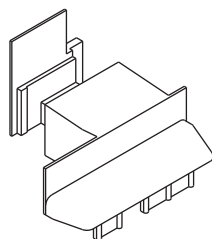

WP 3102

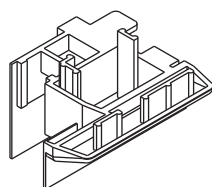

капачка
cap
abdeckkappe
capacele

УСИЛВАЩИ ПРОФИЛИ

Verstaerkungsprofile/ Reinforced profiles/ Armature

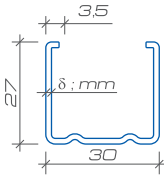
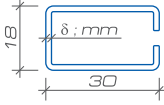
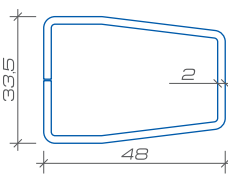
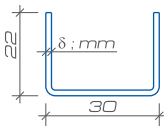
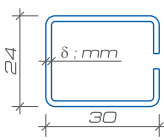
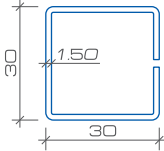
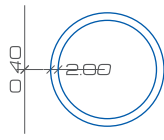
Код	PVC Профил PVC profile PVC profil PVC profil	Усилващ профил Verstaerkungsprofile Reinforced profile Armature	 Инерционен МОМЕНТ Traegheitsmoment Inertia moment momentului inert
V01	WP 3111 WP 3102		$\delta = 1,5$ $I_x = 1,04 \text{ cm}^4$ $I_y = 1,93 \text{ cm}^4$
			$\delta = 2$ $I_x = 1,27 \text{ cm}^4$ $I_y = 2,43 \text{ cm}^4$
V02	WP 4112		$\delta = 1,5$ $I_x = 0,67 \text{ cm}^4$ $I_y = 1,39 \text{ cm}^4$
			$\delta = 2$ $I_x = 0,83 \text{ cm}^4$ $I_y = 1,73 \text{ cm}^4$
V03	WP 4104 WP 4105		$I_x = 4,50 \text{ cm}^4$ $I_y = 8,70 \text{ cm}^4$
V04	WP 3101		$\delta = 1,5$ $I_x = 0,52 \text{ cm}^4$ $I_y = 1,55 \text{ cm}^4$
			$\delta = 2$ $I_x = 0,67 \text{ cm}^4$ $I_y = 1,97 \text{ cm}^4$
V05	WP 3103		$\delta = 1,5$ $I_x = 1,33 \text{ cm}^4$ $I_y = 1,76 \text{ cm}^4$
			$\delta = 2$ $I_x = 1,65 \text{ cm}^4$ $I_y = 2,20 \text{ cm}^4$
V06	WP 4107		$I_x = 2,19 \text{ cm}^4$ $I_y = 2,25 \text{ cm}^4$
V07	WP 4111		$I_x = 4,32 \text{ cm}^4$ $I_y = 4,32 \text{ cm}^4$

УСИЛВАЦИ ПРОФИЛИ

Графики за определяне максималните размери на крилата

Graphiken zur Bestimmung der maximalen Fluegelgrosse

Grafice pentru definirea marimii maxime ale aripilor

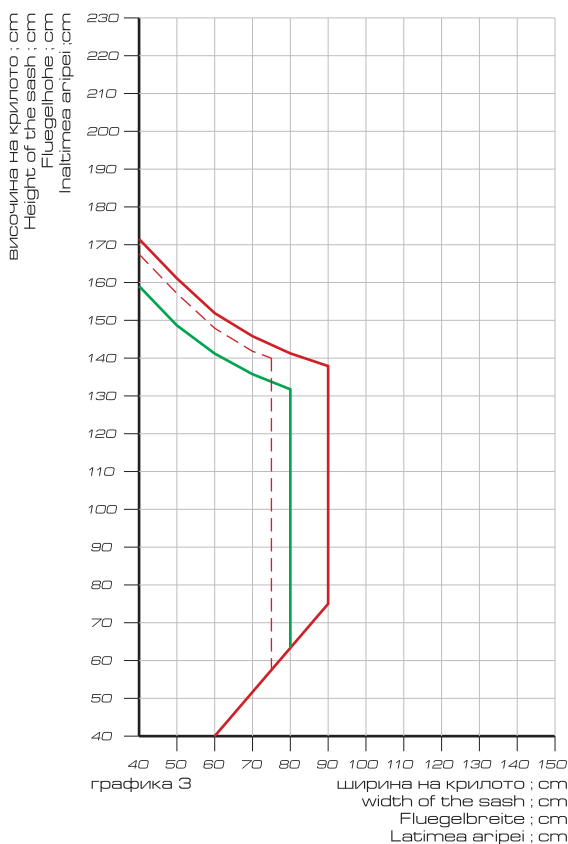
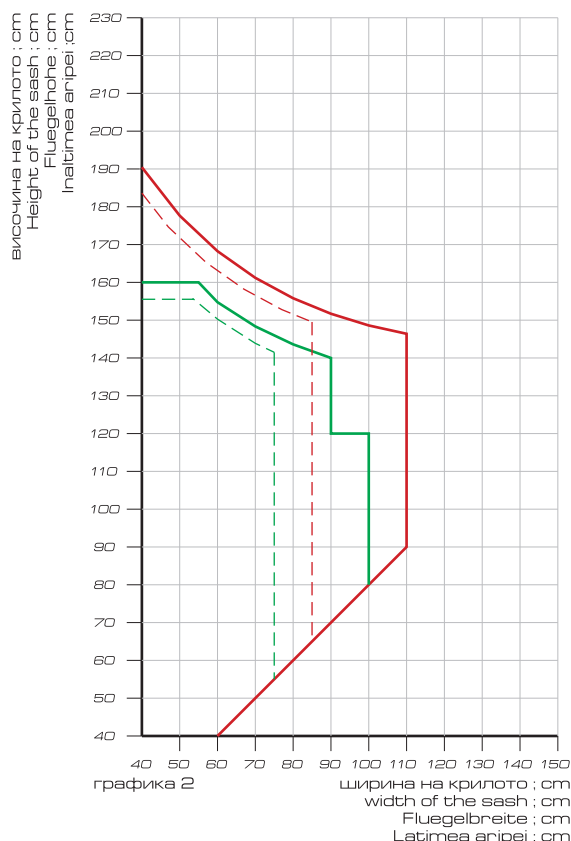
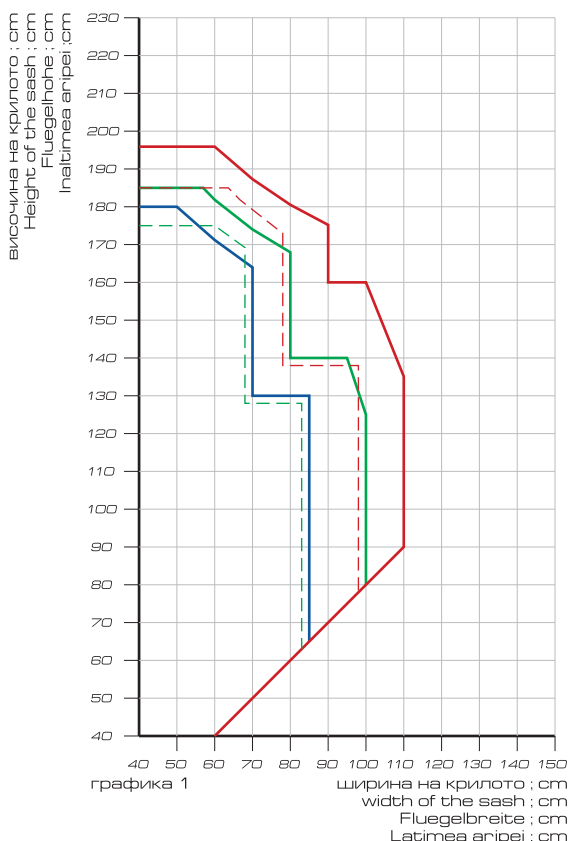

- VO1 / 2,0 mm / $I_x = 1,27 \text{ cm}^4$; $I_y = 2,43 \text{ cm}^4$
- VO1 / 1,5 mm / $I_x = 1,04 \text{ cm}^4$; $I_y = 1,93 \text{ cm}^4$
- VO1 / 1,2 mm / $I_x = 0,86 \text{ cm}^4$; $I_y = 1,59 \text{ cm}^4$

Определяне на необходимия инерционен момент
Calculation of the moment of inertia
Trägheitsmomentenberechnungsformel
Calcularea momentului inert necesar

$$I_n = \frac{W \cdot L^4 \cdot B/2}{1920 \cdot E \cdot f} \left[25 - 40 \left(\frac{B}{L} \right)^2 + 16 \left(\frac{B}{L} \right)^4 \right] ; \text{cm}^4$$

W - ветрово натоварване/ wind pressure/
Winddruck/intensitatea vantului ; N/mm^2

височина на сградата/ height of the building/
Gebaudehohe/ Inaltimea cladirii 0 - 8 m - **W** = 600 Pa
W = 0,0006 N/mm^2 - графика 1

височина на сградата/ height of the building/
Gebaudehohe/ Inaltimea cladirii 8 - 20 m - **W** = 960 Pa
W = 0,0096 N/mm^2 - графика 2

височина на сградата/ height of the building/
Gebaudehohe/ Inaltimea cladirii 20 - 100 m - **W** = 1320 Pa
W = 0,00132 N/mm^2 - графика 3

L - височина/ height/Hohe/ inaltime ; cm

B - ширина/ width/ Breite/ latime ; cm

E - модул на еластичност/ elasticity module/
Elastizitätsmodul/ modulul elasticitatii ($E_{ct} = 210\,000 \text{ N/mm}^2$)

f - допустимо провисване/ slack eligibility/zulassige
Durchbiegung/ arcuinea admisa ($f = L/300$; $f \leq 0,8 \text{ cm}$)

С прекъснатата линия са графиките за избор на усилващ профил при ламиниран профил
The graphics for choosing reinforced profiles for laminated profiles are with dotted line
Die gestrichene Linie kennzeichnet die benoetigte Armierung bei laminiertem Profil
Cu linia punctata sunt indicate graficele pentru alegerea armaturii pentru profilul laminat

ОПРЕДЕЛЯНЕ НА НЕОБХОДИМИЯ ИНЕРЦИОНЕН МОМЕНТ

Calculation of the moment of inertia/ Traegheitsmomentberechnungsformel
 Calcularea momentului inert necesar

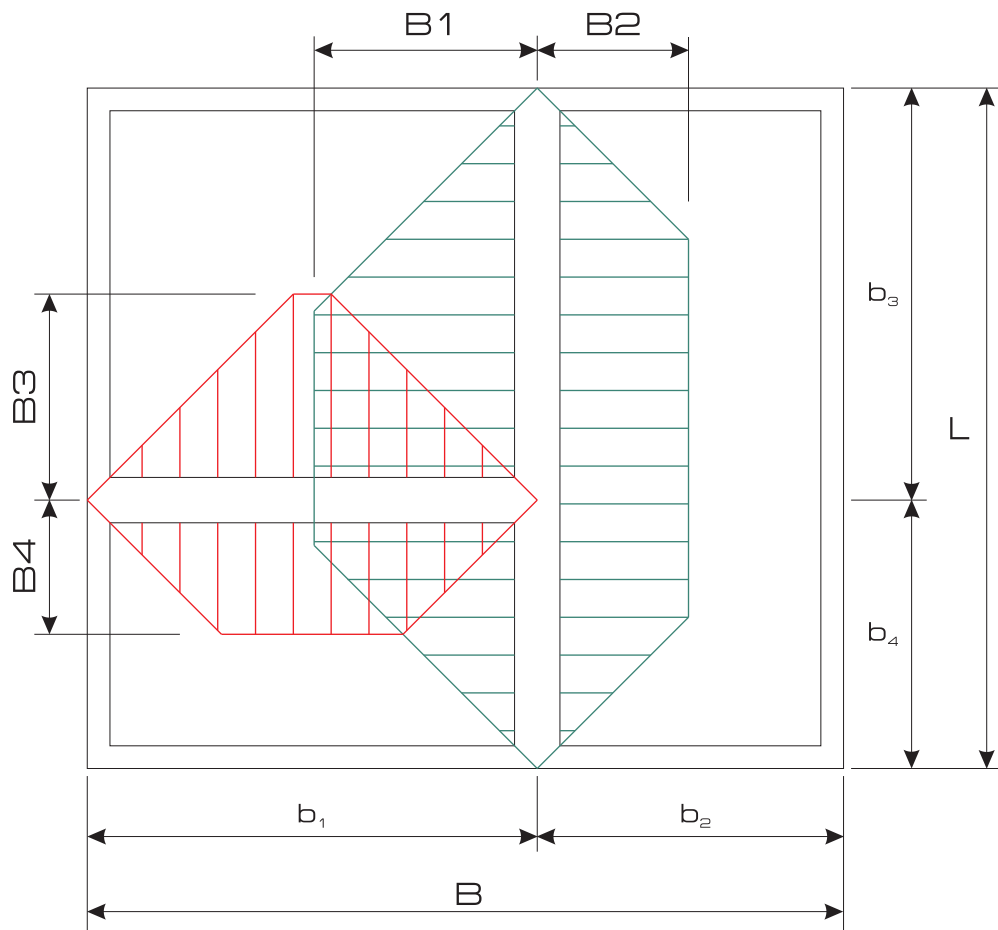

$$I_H = \frac{W \cdot L^4 \cdot B}{1920 \cdot E \cdot f} \left[25 - 40 \left(\frac{B}{L} \right)^2 + 16 \left(\frac{B}{L} \right)^4 \right]; \text{ cm}^4$$

W - ветрово натоварване/ wind pressure/Winddruck/intensitatea vantului ; N/mm²

височина на сградата/ height of the building/Gebaudehohe/ Inaltimea cladirii
 0 - 8 m - W = 600 Pa = 0,0006 N/mm²

височина на сградата/ height of the building/Gebaudehohe/ Inaltimea cladirii
 8 - 20 m - W = 960 Pa = 0,0096 N/mm²

височина на сградата/ height of the building/Gebaudehohe/ Inaltimea cladirii
 20 - 100 m - W = 1320 Pa = 0,00132 N/mm²

L - височина/ height/Hohe/ inaltime ; cm

B - ширина/ width/ Breite/ latime ; cm $B = b_x / 2$; b_x - ширина на клетката ; cm

E - модул на еластичност/ elasticity module/ Elastizitatsmodul/ modulul elasticitatii
 (E _{стомана} - 210 000 N / mm²)

E - модул на еластичност/ elasticity module/ Elastizitatsmodul/ modulul elasticitatii
 (E _{алуминий} - 70 000 N / mm²)

f - допустимо провисване/ slack eligibility/zulassige Durchbiegung/ arcuirea admisa
 (f = L/300 ; f ≤ 0,8 cm)

WP 3111

Прозорец с едно отваряемо крило
Einflügeliges Fenster
A single open window
Fereastra cu o aripa deschisa

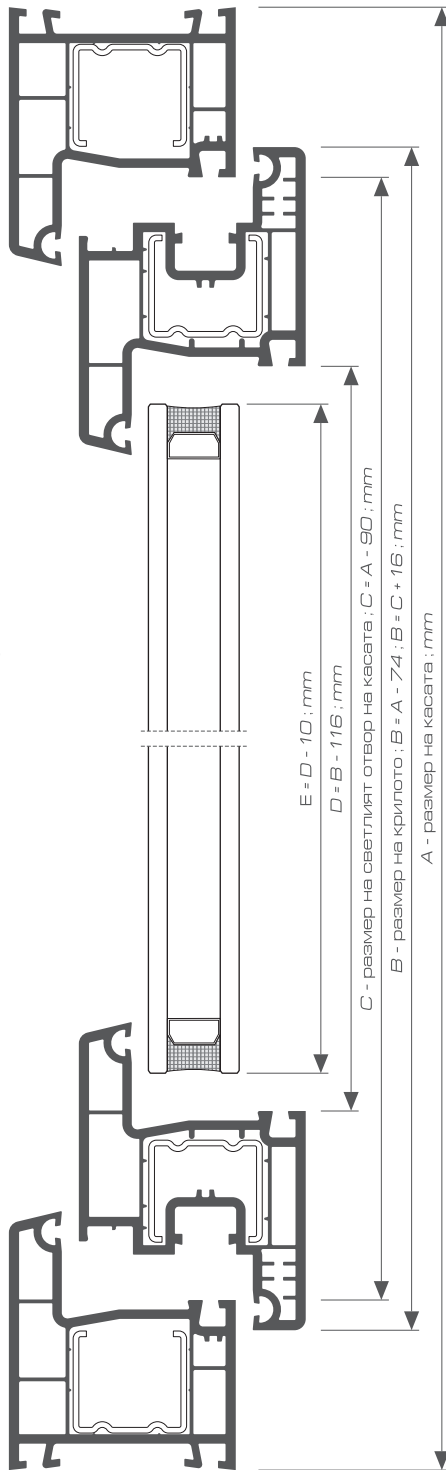

WP 3101

Прозорец с едно отваряемо крило
Einflügeliges Fenster
A single open window
Fereastra cu o aripa deschisa

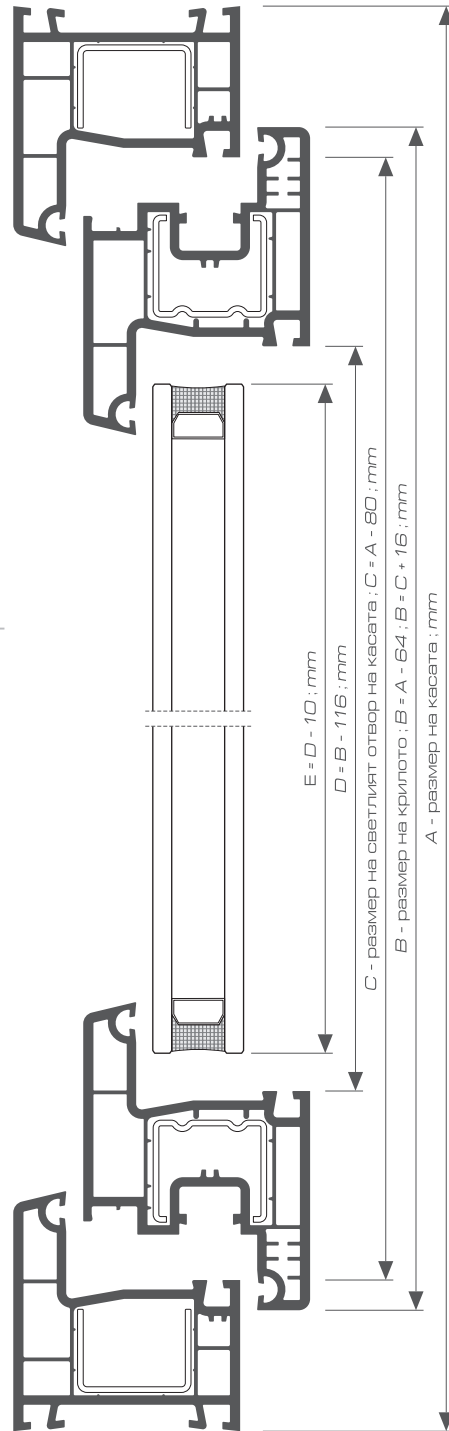

WP 3111

Прозорец с две крила с делител
 Zweiflügeliges Fenster mit Kämpfer
 Double open window with mullion
 Fereastră cu două aripi cu traversa

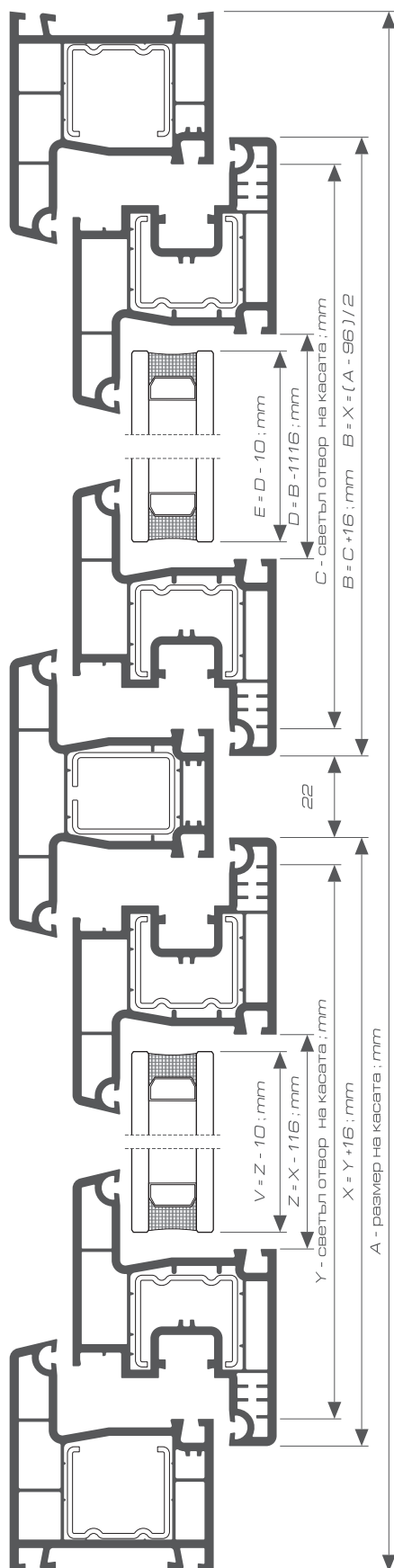

WP 3101

Прозорец с две крила с делител
 Zweiflügeliges Fenster mit Kämpfer
 Double open window with mullion
 Fereastră cu două aripi cu traversa

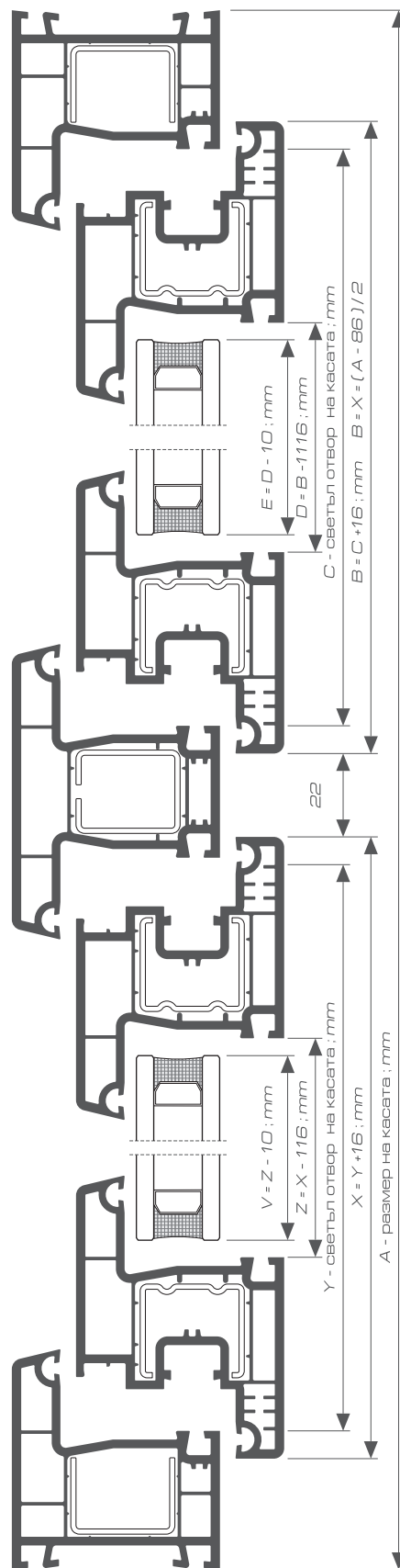

WP 3111

Прозорец с две крила с подвижен делит
Zweiflügeliges Stulpfenster
Double open window with a lap jointed
Fereastră cu două panouri
inversor

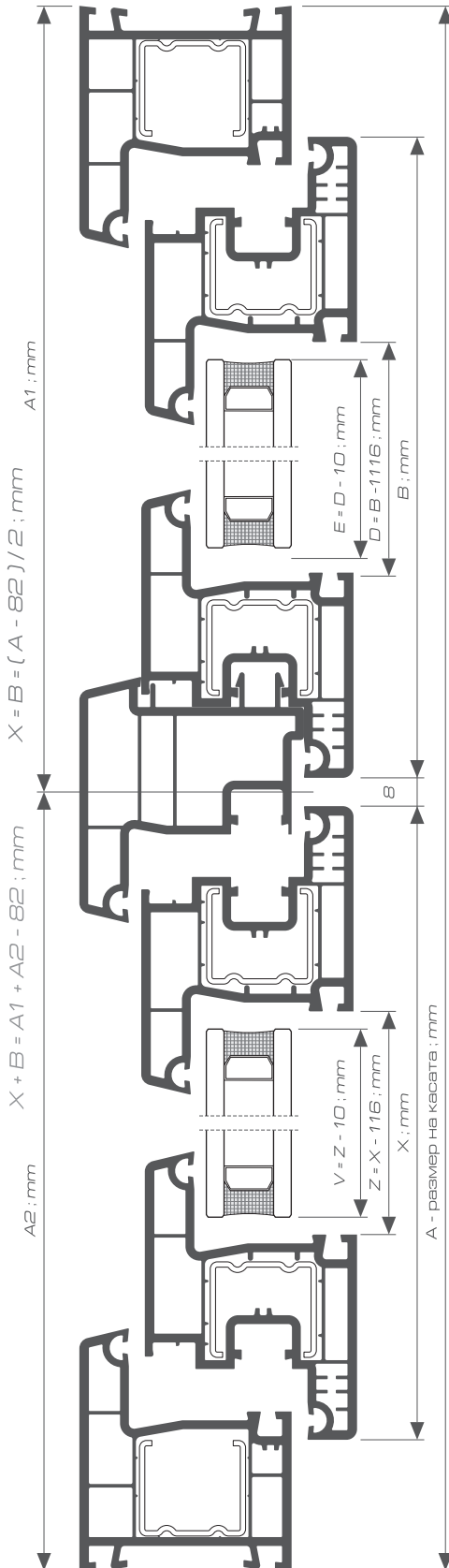

WP 3101

Прозорец с две крила с подвижен делит
Zweiflügeliges Stulpfenster
Double open window with a lap jointed
Fereastră cu două panouri
inversor

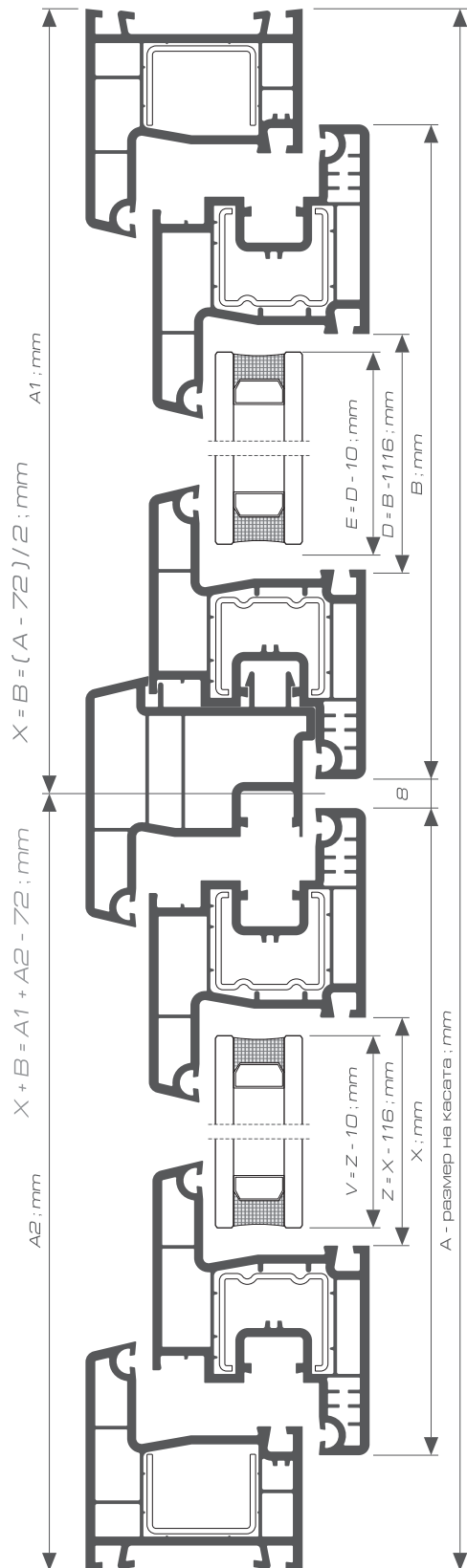

WP 3111

Врата с алуминиев праг
 Tuer mit aluminium tuerschwelle
 Door with aluminium door - sill
 Usa cu prag de aluminiu

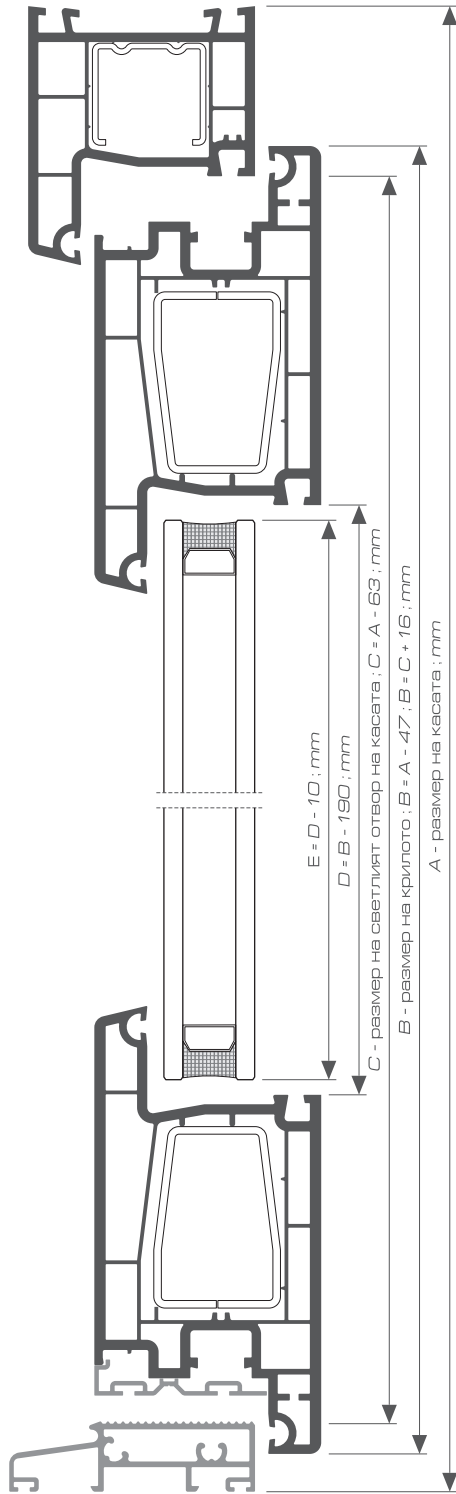

WP 3101

Врата с алуминиев праг
 Tuer mit aluminium tuerschwelle
 Door with aluminium door - sill
 Usa cu prag de aluminiu

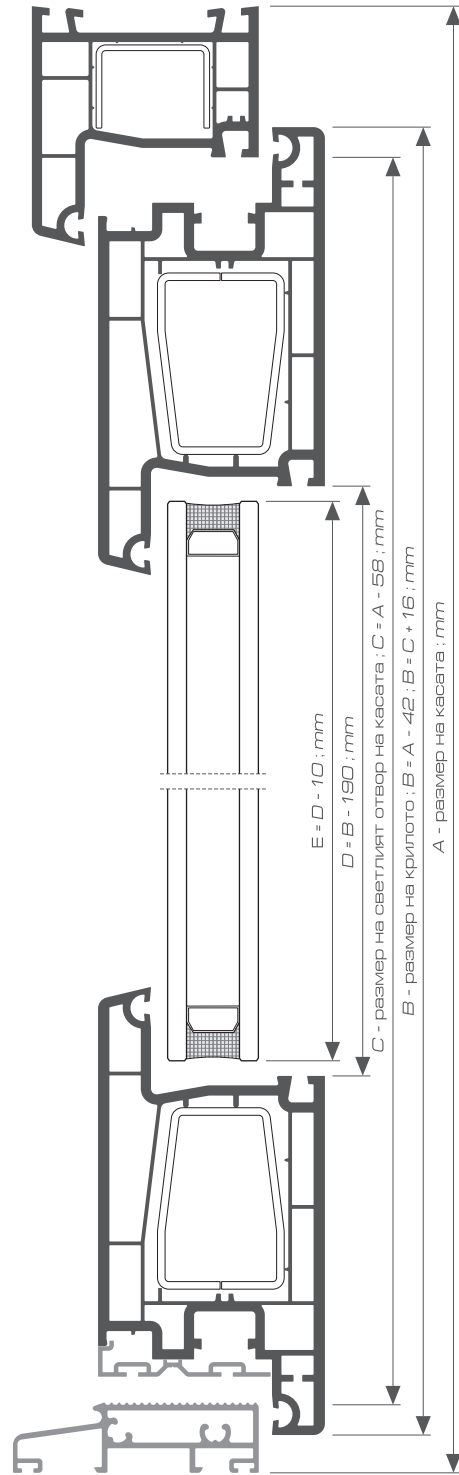

ПРОФИЛИ С ЛАМИНИРАНО ПОКРИТИЕ / АРКИ

Profile mit laminiertem Beschlag Bogen / Arches / Arcade
 Profiles with polish cover
 Profile laminate



светъл орех
 nussbaum hell
 light walnut
 nuc deschis



тъмен орех
 nussbaum dunkel
 dark walnut
 nuc inchis



череша
 kirschbaum
 cherry
 cires



златен дъб
 goldeiche
 golden oak
 stejar auriu

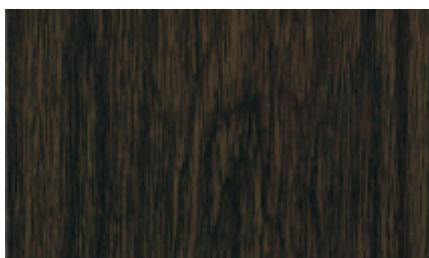

тъмен дъб
 dunkeleiche
 dark oak
 stejar inchis

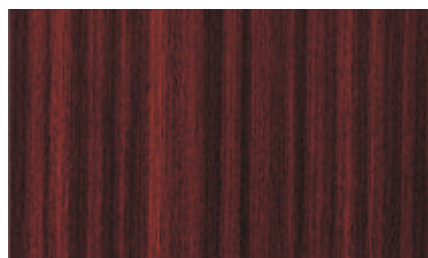

махагон
 mahagoni
 mahogany
 mahon

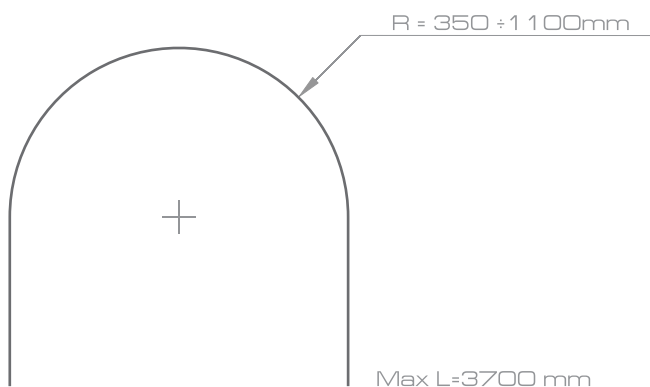
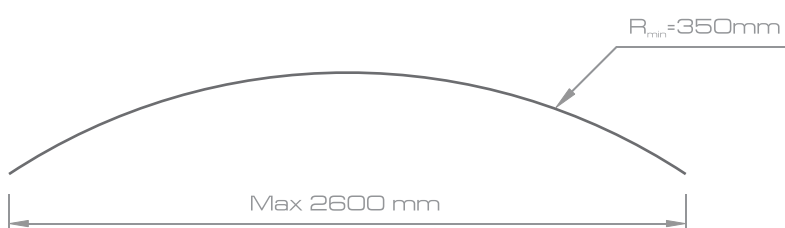

Дъги:

Минимален радиус на дъгата: 350mm
 Максимална дължина на хордата: 2600 mm

Bogen:

Min. Radius des Bogens: 350mm
 Max. Länge der Sehne 2600 mm

Arcs:

Minimum radius of the arc: 350 mm
 Maximum length of the chord: 2600 mm

Arcade:

Raza minima a arcadei: 350mm,
 Raza maxima: 2860mm,
 Raza minima a arcadei: 2000mm

Полуокръжности:

Минимален радиус на полуокръжността: 350mm
 максимален радиус: 1100 mm
 Максимална дължина на огъвката, заедно с двете вертикали: 3700mm.

Halbkreise:

min. Radius des Halbkreises: 350mm,
 max. Radius: 1100 mm
 Max. Länge der Biegung samt beiden Vertikalen: 3700 mm.

Semicircles:

Minimum radius of the semicircle: 350mm
 maximum radius: 1100 mm
 Maximum length of the curve together with the two verticals: 3700mm.

Semicircuri:

Raza minima a semicercurilor: 350mm
 Raza maxima: 1100 mm
 Lungimea maxima a arcadei impreuna cu cele doua verticale: 3700mm

Централен офис: София, бул. "Илиенско шосе" №8, тел. +359 2/9360093, факс +359 2/9360897
Zentrale: 8 Iliensko Schosse Str., 1220 Sofia, Bulgaria, Tel. +359 2/9360093, Fax +359 2/9360897
Head office: 8 Iliensko Shouse str., 1220 Sofia, Bulgaria, Tel. + 359 2/9360093, Fax +359 2/9360897
Buroul central: Sofia,bd."Iliensko sose" Nr.8,tel +359 2/9360093,fax +359 2/9360897
www.weissprofil.bg weiss.profil@dir.bg